



---

Measurement Systems



*Datascan*  
*Installation*  
*and*  
*User*  
*Guide*

Supplied By

## **Copyright © 2010 Measurement Systems Ltd**

All rights reserved. The information in this document is protected by copyright. It may not be reproduced or transmitted in any form or by any means, mechanical, electronic, photocopying or recording including translation into any other language without the prior consent in writing of Measurement Systems.

### **Trademarks:**

Trademark names are used in this manual. Measurement Systems acknowledges those and has no intention to infringe the trademark, it uses the names in an editorial fashion to the benefit of the trademark owner.

### **Disclaimer:**

Measurement Systems assumes no responsibility for any errors or omissions in this Manual. The information contained within is subject to change without notice.

### **Accuracy Statement:**

The published specifications as printed on the Datascan Modules Data sheets or within the Datascan Technical Reference Manual are 12-month accuracies, after which time the units should be returned to the supplier whose address is on the title page of this manual

Measurement Systems Ltd  
Newbury  
Berkshire  
England

Tel: +44 (0) 1635 576800  
Fax: +44 (0) 1635 31023

Web: [www.measurementsystems.co.uk](http://www.measurementsystems.co.uk)

---



---

# Contents

---

<b>1. INTRODUCTION</b> .....	<b>1</b>
1.1 GENERAL .....	1
1.2 DATASCAN MODULE RANGE.....	1
1.2.1 <i>Measurement Processors</i> .....	1
1.2.2 <i>Analog Expansion Scanner Modules</i> .....	2
1.2.3 <i>Digital Expansion Scanner Modules</i> .....	2
1.2.4 <i>Gateway and Peripheral Modules</i> .....	3
1.2.5 <i>Typical Datascan Installation</i> .....	3
1.3 MEASUREMENT PROCESSOR.....	4
1.3.1 <i>Scanner Expansion Bus</i> .....	4
1.3.2 <i>RS232 Isolated Local Interface</i> .....	5
1.3.3 <i>RS485 Isolated Network Interface</i> .....	5
1.3.4 <i>Power Supply</i> .....	5
1.4 SYSTEM SPECIFICATION .....	6
1.4.1 <i>Power Requirements &amp; Dimensions</i> .....	7
<b>2. INSTALLATION &amp; CONFIGURATION</b> .....	<b>9</b>
2.1 MECHANICAL .....	9
2.2 MODULE ELECTRICAL INSTALLATION DETAILS .....	10
2.2.1 <i>7010 Measurement Processor</i> .....	10
2.2.2 <i>7200 Installation Details</i> .....	11
2.2.3 <i>7300 Installation Details</i> .....	12
2.2.4 <i>Typical Expansion Scanner</i> .....	13
2.2.5 <i>Digital Input Expansion Scanners</i> .....	13
2.2.6 <i>Analog Output Expansion Scanners</i> .....	14
2.2.7 <i>7041Timer Counter Installation Details</i> .....	15
2.2.8 <i>7011 Installation Details</i> .....	16
2.2.9 <i>Power Supply Cabling</i> .....	17
2.2.10 <i>Local Mains Frequency</i> .....	17
2.2.11 <i>Earth Terminal</i> .....	17
2.2.12 <i>RS485 Network Cabling</i> .....	18
2.2.13 <i>RS232 Interface Cabling</i> .....	20
2.2.14 <i>Expansion Bus Cabling</i> .....	22
2.2.15 <i>I/O Cabling</i> .....	22
2.2.16 <i>Installation Notice for 7300 Processor Modules</i> .....	23
2.2.17 <i>Installation and Use Recommendations</i> .....	24
<b>3. DATASCAN SYSTEM CONFIGURATION</b> .....	<b>25</b>
3.1 DATASCAN SYSTEM LAYOUT CONSIDERATIONS .....	25
3.1.1 <i>Using Digital Input Expansion Modules</i> .....	25
3.1.2 <i>Using Analog Output Expansion Modules</i> .....	25
3.1.3 <i>Using Isolated Analog Input Modules</i> .....	25
3.2 CHANNEL ADDRESS CONFIGURATION .....	26

---

**Contents**

3.2.1	7010 Measurement Processor.....	26
3.2.2	7200 Measurement Processors.....	26
3.2.3	7300 Analog Measurement Processors.....	27
3.2.4	General Considerations.....	27
3.2.5	Channel Address Set-up.....	27
3.3	RS485 NETWORK CONFIGURATION.....	27
3.3.1	Network Switch Settings.....	28
<b>4.</b>	<b>MEASUREMENT PROCESSORS.....</b>	<b>29</b>
4.1	7200 MEASUREMENT PROCESSORS (NON EXPANDABLE).....	29
4.2	7300 MEASUREMENT PROCESSORS (EXPANDABLE).....	30
<b>5.</b>	<b>SCANNER EXPANSION MODULES.....</b>	<b>31</b>
5.1	ANALOG SCANNER EXPANSION MODULES.....	31
5.2	DIGITAL SCANNER EXPANSION MODULES.....	32
5.2.1	Digital Input Channels.....	32
5.2.2	Digital Output Channels.....	33
5.3	COUNTER TIMER MODULE 7041.....	34
<b>6.</b>	<b>SENSOR CONNECTIONS.....</b>	<b>35</b>
6.1	COMMON MODE RANGE (NON ISOLATED MODULES).....	36
6.2	ANALOG INPUTS.....	37
6.2.1	2 Pole Inputs.....	38
6.2.2	3 Pole Inputs.....	41
6.2.3	4 Pole Inputs (Isolated).....	45
6.2.4	6 Pole Inputs.....	48
6.3	DIGITAL INPUTS.....	56
6.3.1	Volt Free Contact Energisation.....	57
6.3.2	Overload Protection.....	58
6.4	DIGITAL OUTPUTS.....	59
6.5	ANALOG OUTPUTS.....	60
6.5.1	Voltage Outputs.....	60
6.5.2	Current Outputs.....	60
<b>7.</b>	<b>NETWORK GATEWAY MODULES.....</b>	<b>61</b>
7.1	7011 NETWORK GATEWAY MODULE.....	61
7.2	DATASCAN 7011-M MODBUS™ INTERFACE.....	62
<b>8.</b>	<b>CHANNEL ADDRESS SWITCH TABLES.....</b>	<b>63</b>
<b>9.</b>	<b>TROUBLESHOOTING.....</b>	<b>73</b>
9.1	TYPICAL PROBLEMS.....	73
9.1.1	No host communications.....	73
9.1.2	Incorrect readings.....	73
9.1.3	No networking facilities.....	74
9.1.4	Datascan Hardware reset.....	74
9.1.5	Powering up the Datascan.....	74
9.1.6	LED Status indicators.....	75
9.2	GENERAL GUIDELINES FOR A FAULT FREE SYSTEM.....	76

		<b>Contents</b>
9.2.1	<i>Configuration Switches</i> .....	76
9.2.2	<i>Unused inputs</i> .....	76
9.2.3	<i>Analog inputs</i> .....	76
9.2.4	<i>Analog outputs</i> .....	77
9.2.5	<i>Common mode problems with non isolated modules</i> .....	77
9.2.6	<i>Network termination</i> .....	77
9.2.7	<i>Channel Addressing</i> .....	77
9.3	TRUBLESHOOTING USING WINDOWS TERMINAL EMULATOR .....	78
9.3.1	<i>Configuring Windows Terminal</i> .....	78
9.3.2	<i>Talking To Datascan</i> .....	80
<b>10.</b>	<b>DATASCAN ERRORS</b> .....	<b>85</b>
10.1	COMMAND ERRORS .....	85
10.2	RESULT ERRORS .....	86
<b>11.</b>	<b>INDEX</b> .....	<b>87</b>

**Contents**

---

# 1. Introduction

---

The Datascan Installation and User Guide is a brief introduction to the Datascan 7000 series of Data Acquisition Modules. The guide provides all necessary information to install the modules, configure the various DIP switches and connect the input and output sensors.

For more detailed information including the in built software commands and specification refer to the Datascan Technical Reference Manual obtainable from your local Datascan Distributor. Detailed specifications for each module can also be obtained from the respective data sheets.

## 1.1 General

The Datascan 7000 is a series of intelligent measurement and data collection units developed for factory, industrial and scientific data acquisition applications. Datascan 7000 provides new concepts and standards in interfacing sensors to computers.

Due to its modular concept, a Datascan 7000 system can vary from a minimum configuration, consisting of a single Measurement Module, with suitable scanning units (see Figure 1.1), up to a 'full blown' 1000 channel system comprising many Measurement Modules and Scanner Modules linked by their own proprietary RS485 local area network.

## 1.2 Datascan Module Range

### 1.2.1 Measurement Processors

Measurement Processors are modules that contain the A/D Converter, microprocessor with battery backup memory and power supply. They also provide the RS232 link capabilities to a host computer or local monitor as well as the isolated RS485 network interface.

- 7010** A measurement processor that has no on board channel inputs but does provide full local channel expansion capability (up to 256 channels per module).
- 7220** A measurement processor that provides directly 16 analog inputs. This module can be connected to the RS485 Datascan network but does not have any local channel expansion capability.

- 7221** A measurement processor that provides directly 8 analog inputs including channel excitation. This module can be connected to the RS485 Datascan network but does not have any local channel expansion capability.
- 7250** A measurement processor that provides directly 8 analog inputs and 8 analog outputs. This module can be connected to the RS485 Datascan network but does not have any local channel expansion capability.
- 7320** A measurement processor that provides directly 16 analog inputs as well as full local channel expansion capability (up to 256 channels per module).
- 7321** A measurement processor that provides directly 8 analog inputs, including channel excitation and full local channel expansion capability (up to 256 channels per module).
- 7327** A measurement processor that provides directly 16-reed relay isolated analog inputs as well as full local channel expansion capability (up to 256 channels per module).

## 1.2.2 Analog Expansion Scanner Modules

Analog expansion modules provide additional local analog input and output capabilities to the 7010, 7320, 7321 and 7327 Measurement Processors. Up to 256 channels can be connected to the Measurement Processor. See Section 5 for further information on each scanner module.

- 7020** Provides 16 analog input channels per scanner.
- 7021** Provides 8 analog input channels per scanner, with excitation for transducers.
- 7026** Provides 8 channels of solid-state isolated analog inputs.
- 7027** Provides 16 channels of isolated (reed relay) analog inputs.
- 7050** Provides 8 analog input channels & 8 analog output channels.

## 1.2.3 Digital Expansion Scanner Modules

Digital expansion modules provide digital input and output capabilities to the 7010, 7320, 7321 and 7327 measurement Processors. Up to 256 channels can be connected to the Measurement Processor. See Section 5 for further information on each scanner module.

- 7031** Provides 16 digital input channels.
- 7035** Provides 16 digital output channels.
- 7036** Provides 8 digital input and 8 digital output channel capability.
- 7041** Counter Timer module provides pulse count and frequency measurement capability up to 3.5Khz. 8 input channels up to 3.5Khz and 8 up to 10 Hz.

## 1.2.4 Gateway and Peripheral Modules

**7011** Provides a low cost method of connecting a PC or local terminal to a Datascan Network when there is no local measurement processor.

**7011-M** The 7011-M is a Modbus™ protocol converter for the Datascan System. The module interfaces a Modbus™ ASCII protocol master for configuration, reading and the writing of channels on the Datascan System.

## 1.2.5 Typical Datascan Installation

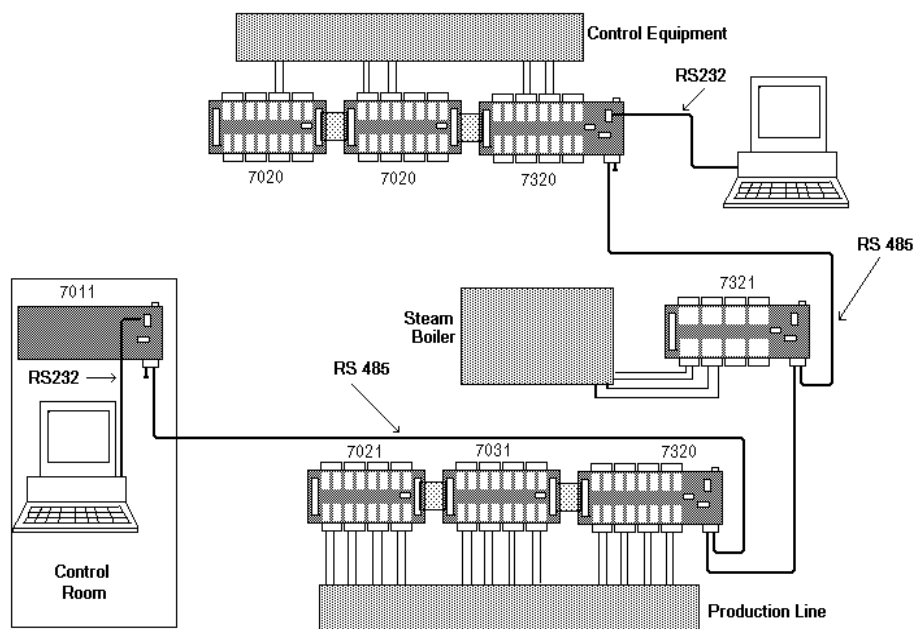

FIGURE 1.1 TYPICAL DATASCAN INSTALLATION

Figure 1.1 depicts a typical Datascan installation. The host computer is located in a factory office some distance from the main Datascan system. A 7011 Gateway module provides a local RS232 link to the host computer as well as linking to the rest of the Datascan Modules via the RS485 network.

A 7320 Analog Measurement processor module is sited adjacent to the production line. This 7320 and attached scanner modules collect information from the line. Connected to the RS485 network is a single 7321 located in the boiler room. It collects data from the boiler. In the equipment control room further Datascan modules acquire data and also provide output control signals.

It can be seen from this example that by positioning the Datascan modules close to the sensors they are measuring and then connecting the modules via the RS485 network keeps the wiring costs of the system to a minimum.

## 1.3 Measurement Processor

The heart of the Datascan System is the Measurement Processor. Each processor can be used autonomously or as part of a larger system via the Datascan network (see Figure 1.1).

The measurement processor performs the measurement and control of the Datascan system. Measurement is carried out by a powerful Analog to Digital converter, which can be programmed to provide either 16 or 14 bits of resolution and is sensitive to 0.625 $\mu$ V.

Further channel expansion, except 7200 processors, is by means of a local expansion bus providing a total of 256 channels connected directly to the local expansion bus. The channels can be a mixture of analog and digital inputs; analog and digital outputs; and pulse inputs.

Each measurement processor module has two communication ports, an isolated RS232 port for communication with host computers or local display terminals, and an isolated RS485 network port for connecting up to 32 measurement modules over a network distributed up to 1.2 km. The isolated nature of these ports prevents ground loop problems and protects the network and host computer in the event of high voltages entering the measurement modules.

The CMOS design of the module limits the typical power requirements to less than 2 watts. Power is supplied as 24V AC or DC (7300 24V DC only) enabling it to be easily installed into factory supplies.

### 1.3.1 Scanner Expansion Bus

Each 7300 series and 7010 module provide an expansion bus for the connection to Datascan scanner modules.

The scanner modules are simply daisy chained using the 26-way connector on the modules. Up to 256 channels, both analog and digital, inputs and outputs including those on the 7300 module can be connected to a single 7010 or 7300 Measurement Processor through the expansion bus. These can be connected locally over a total distance of 10 metres.

**Note:**

The maximum number of channels connected to a 7010 or 7300 series module are reduced when the following scanner modules are added: 7026, 7027, 7050, 7031, and 7036. Refer to section 3.1 for further information.

### 1.3.2 RS232 Isolated Local Interface

The serial port is isolated to 500V DC and enables the user to communicate with the Measurement Processors using a standard computer or VDU(TV 925/VT100 etc.). The baud rate is switch selectable between 4800, 9600, 19200, or 38400.

### 1.3.3 RS485 Isolated Network Interface

One of the unique features of the Datascan 7000 series of Measurement Processors is its distributed networking capability. Each processor module can operate autonomously with its own local input and output modules, or alternatively can be connected to a network cluster of up to 32 measurement processors.

The token passing network can operate over a distance of 1.2 Km (4000ft) using a standard screened twisted pair cable and can support a total of 32 Measurement Processors, with up to 1000 channels of all types being distributed along the network.

The network is self-configuring. This means that units can be added or removed from the network with minimal disturbance to the data transmission.

The network is fully isolated to 500 Volts, protecting other modules on the network in the unlikely event of mains voltage being applied to the network or to a specific module on the network.

### 1.3.4 Power Supply

The power supply of the Datascan Measurement processor provides the power for both the local module and that of the modules attached to it via the scanner expansion bus. The unit will accept an input supply of 24V AC or DC. ( 7300 24V DC only)

## 1.4 System Specification

**ADC Resolution** 16 bit or 14 Bit (7027 16 bit only)  
Software Programmable

**ADC Measurement Speed**  
(Individual Channel Speed Selection) 40 conversions / sec at 16 bit  
400 conversions / sec at 14 Bit

**Measurement speed** 1 Hz typical

### RS232 Host Communication

Baud rates 4800, 9600, 19200 38400 (Switch  
selectable)  
RS232 Cable length 10m maximum  
RS232 Isolation 500V DC

### Local Expansion Bus

Total no. of channels 256 max.  
Expansion cable 26 way ribbon cable (supplied)  
Maximum cable length 10 metres

### RS485 Network

Electrical specification RS485  
Transmission 93.75Kbaud  
RS485 Isolation 500 V DC  
Data Rate 1000 results/second  
Total Channels per network 1000  
Maximum Length 1.2Km (4000 ft)  
Maximum number of nodes 32  
Recommended Cable Types Belden 9207 (up to 1.2km)  
Belden 8761 (up to 300m)

### Environmental

Operating Temperature -10 to 60 °C  
Storage Temperature -20 to 80 °C  
Relative Humidity 0 - 90% RH non condensing

## 1.4.1 Power Requirements & Dimensions

### Processor and Network Modules

Module	Power Supply	Max Power	Dimensions (mm)			Weight Grams
			Width	Height	Depth	
7010	24V AC/DC	0.5 A	230	123	80	750
7011	24V AC/DC	0.1 A	230	123	80	700
7041	24V AC/DC	0.1 A	230	123	80	750
7220	24V AC/DC	0.1 A	230	123	80	750
7221	24V AC/DC	0.1 A	230	123	80	750
7250	24V AC/DC	0.3 A	230	123	80	750
7320	24V DC	0.5 A	230	123	80	750
7321	24V DC	0.5 A	230	123	80	750
7327	24V DC	0.5 A	230	123	107	1300

### Scanner Expansion Modules

Module	Power Supply	Max Power	Dimensions (mm)			Weight Grams
			Width	Height	Depth	
7020		200mW	178	123	80	450
7021		200mW	178	123	80	450
7026		400mW	178	123	82	850
7027		300mW	178	123	80	1000
7031		220mW	178	123	80	650
7035		200mW	178	123	80	650
7036		220mW	178	123	80	650
7050		1.5W	178	123	80	600

#### Note:

When using 7050 Modules. If the module is being used as a set of 4 to 20mA sources, an external, isolated 24V DC supply **MUST** be connected (e.g. 7981), to the auxiliary 24V input connections on each 7050 module.



## 2. Installation & Configuration

### 2.1 Mechanical

The Datascan 7000 System has been designed for ease of installation and configuration. The modules themselves clip on to industry standard DIN rails which can be mounted in standard housings as shown in Figure 2.1.

**NOTE:**  
 Although standard industry housings are suitable for the Datascan 7000 series, the housings should be selected to suit their local environmental conditions.

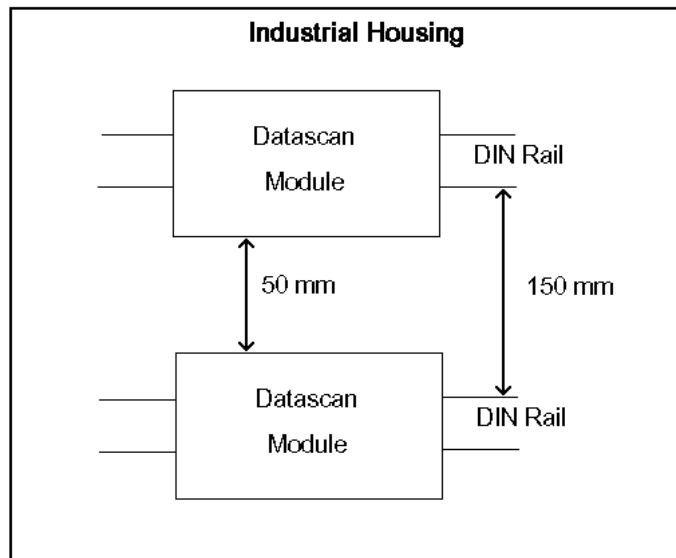

FIGURE 2.1 MECHANICAL INSTALLATION DETAILS

The recommended minimum distances allow room for sensor cabling.

## 2.2 Module Electrical Installation Details

The following figures identify the various installation and configuration features.

### 2.2.1 7010 Measurement Processor

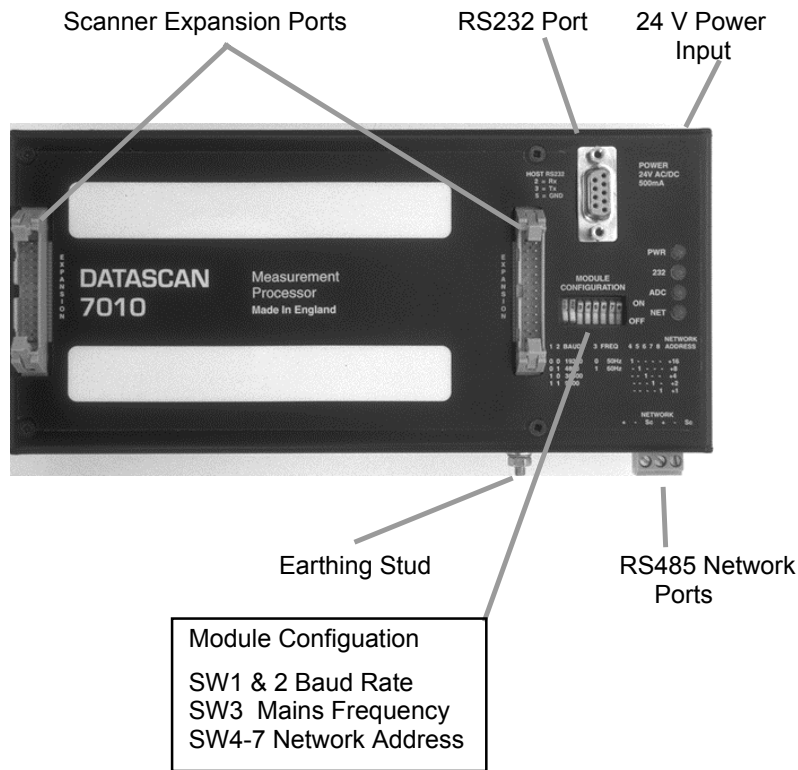

FIGURE 2.2 7010 INSTALLATION DETAIL

**Note:**

If any of the Datascan System set-up switches are changed after power up they will have no effect until the power to the module is removed and then re-applied.

## 2.2.2 7200 Installation Details

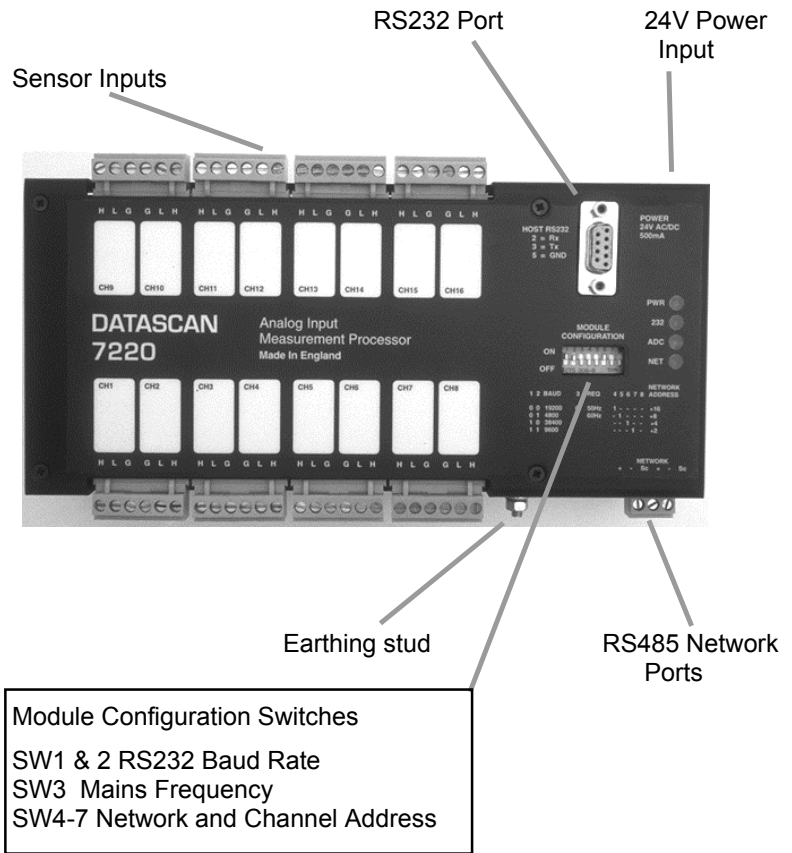

FIGURE 2.3 7200 SERIES INSTALLATION DETAIL

**Note:**  
 If any of the Datascan System set-up switches are changed after power up they will have no effect until the power to the module is removed and then re-applied.

## 2.2.3 7300 Installation Details

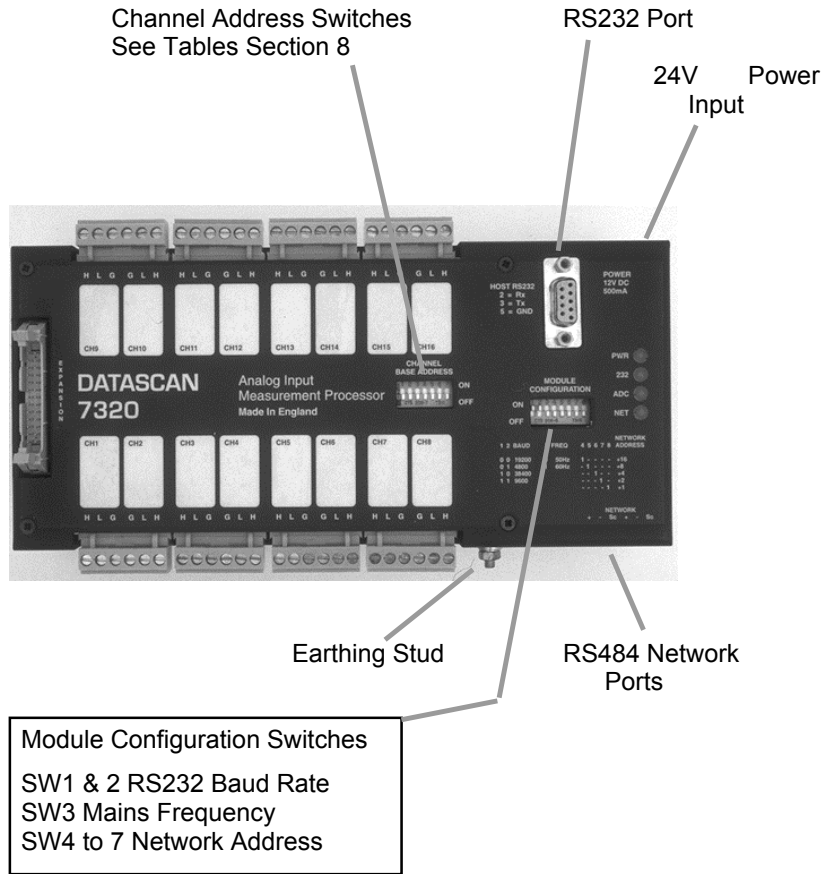

FIGURE 2.4 7300 SERIES INSTALLATION DETAILS

**Note:**  
 If any of the Datascan System set-up switches are changed after power up they will have no effect until the power to the module is removed and then re-applied.

## 2.2.4 Typical Expansion Scanner

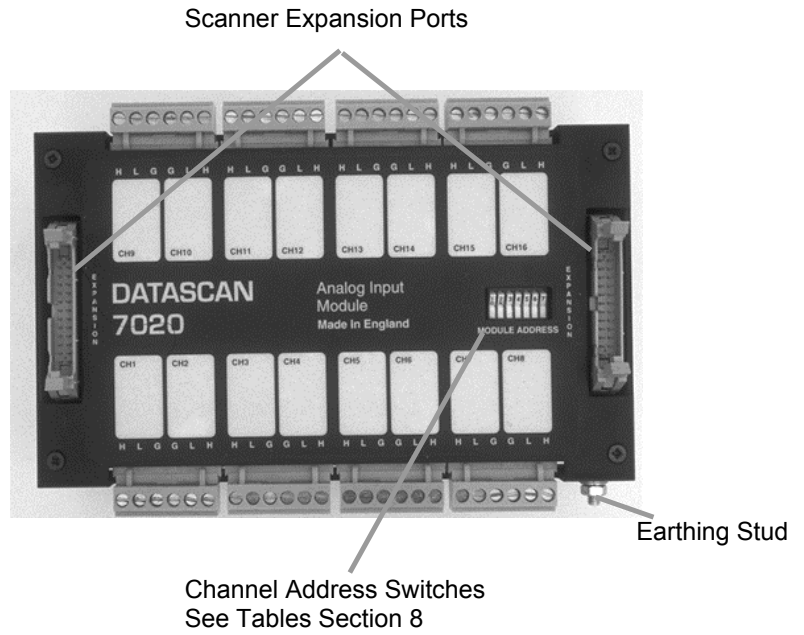

FIGURE 2.5 EXPANSION SCANNER INSTALLATION DETAILS

## 2.2.5 Digital Input Expansion Scanners

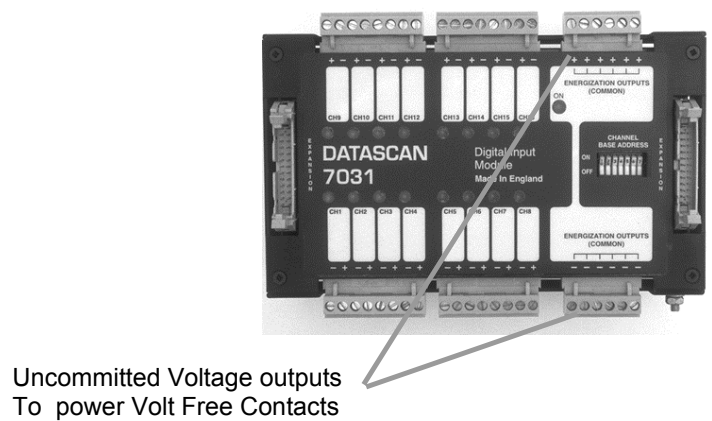

FIGURE 2.6 DIGITAL INPUT VOLT FREE ENERGISATION

## 2.2.6 Analog Output Expansion Scanners

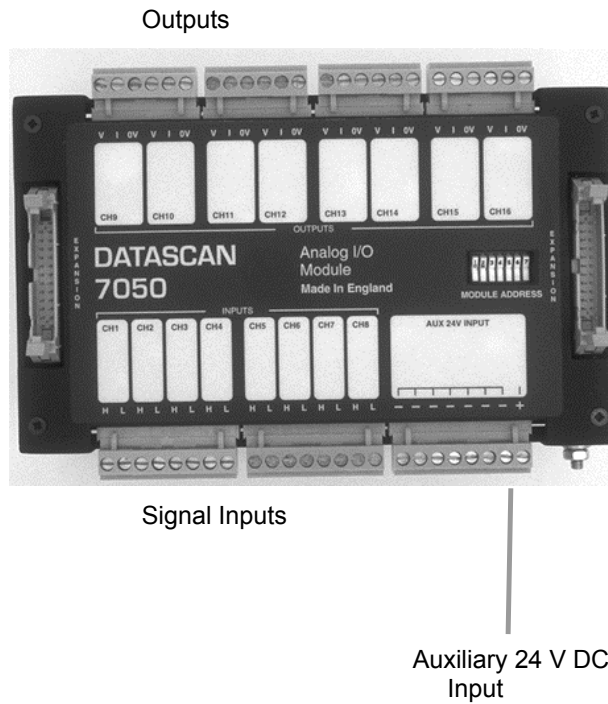

FIGURE 2.7 7050 AUXILIARY POWER INPUT

**Note:**

If any of the Datascan System set-up switches are changed after power up they will have no effect until the power to the module is removed and then re-applied.

## 2.2.7 7041 Timer Counter Installation Details

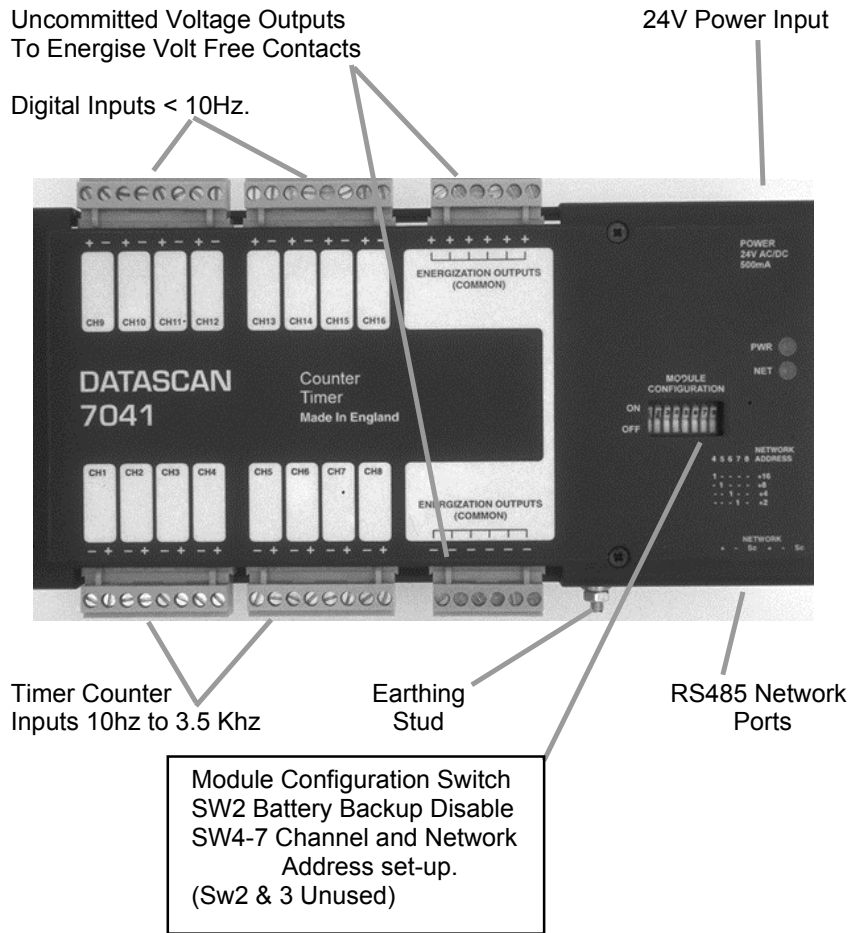

FIGURE 2.8 7041 INSTALLATION DETAILS

**Note:**

If any of the Datascan System set-up switches are changed after power up they will have no effect until the power to the module is removed and then re-applied.

## 2.2.8 7011 Installation Details

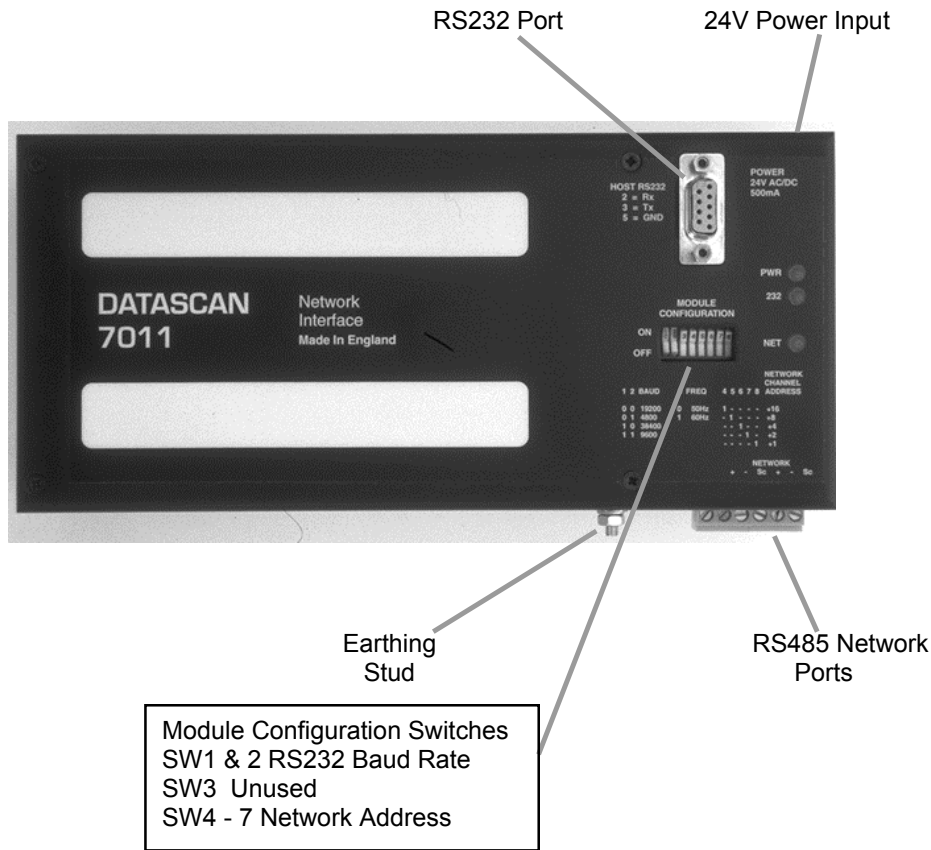

FIGURE 2.9 7011 INSTALLATION DETAILS

**Note:**  
If any of the Datascan System set-up switches are changed after power up they will have no effect until the power to the module is removed and then re-applied.

## 2.2.9 Power Supply Cabling

The measurement processors, Timer Counter module, gateway and extender modules need to be connected to a 24 V power supply, see Table 2.1.

Modules	24V DC +/-5% @ 0.5 Amps	24V AC/DC +/-10% @ 0.5 Amps
7320, 7321, 7327	✓	
7010, 7220, 7221, 7250		✓
7041		✓
7011,		✓

**TABLE 2.1 PROCESSOR MODULE POWER REQUIREMENTS**

The power input to all modules except the 7300 series is not polarity conscious but for information the screw connector nearest the end of the module is the NEGATIVE terminal for all types. On the 7300 series correct polarity must be observed and this is labelled on the module case.

## 2.2.10 Local Mains Frequency

To maintain maximum noise rejection a switch is provided on every Measurement Processor Module to match the module to the local mains frequency. On the processor modules set the switch to select either 50 or 60 Hz.

Frequency	DIP Switch No 3
50 Hz	Off
60Hz	On

## 2.2.11 Earth Terminal

Provision is made on each Datascan module to allow the metal case to be earthed. The earthing stud is shown in Figures 2.2 to 2.7.

## 2.2.12 RS485 Network Cabling

The network cabling between Datascan Measurement modules requires the minimum of ducting space by using only screened twisted pair cable. The cable is connected to the Measurement Processor modules via 6-way dual network connectors using 3-way disconnectable screw terminals as shown in Figure 2.2 to 2.7.

### 2.2.12.1 RS485 Cable Connection

Dual network connectors are provided on each Measurement Module to make daisy chaining a simple task. The total maximum cable length within a Datascan Network is 1.2Km (4000 ft) as shown in figure 2.9.

Recommended Cable	Maximum Distance
Belden 8761	up to 300 metres
Belden 9207	up to 1.2 Kilometres

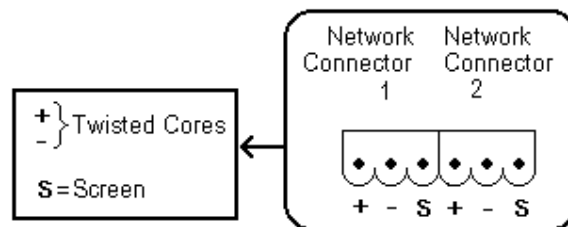

FIGURE 2.10 RS485 NETWORK CABLE CONNECTION

**Note:**

To avoid network problems use recommended cable types, avoid the use of different cable types. Avoid using ducting containing high power cables.

### 2.2.12.2 Network Termination.

Provided with each Measurement Processor is a Network Terminator. A network terminator **must** be connected at each end of the Datascan Network to ensure that even over long distances the leading and trailing edges of the data pulse remains square. The terminator is connected between to the + and – terminals of the spare network connector of the module at the ends of the network. See Figure 2.8.

**Note:**  
**If the network is used, it MUST be terminated at each end using the Datascan Network Terminators ( see Figure 2.4)**

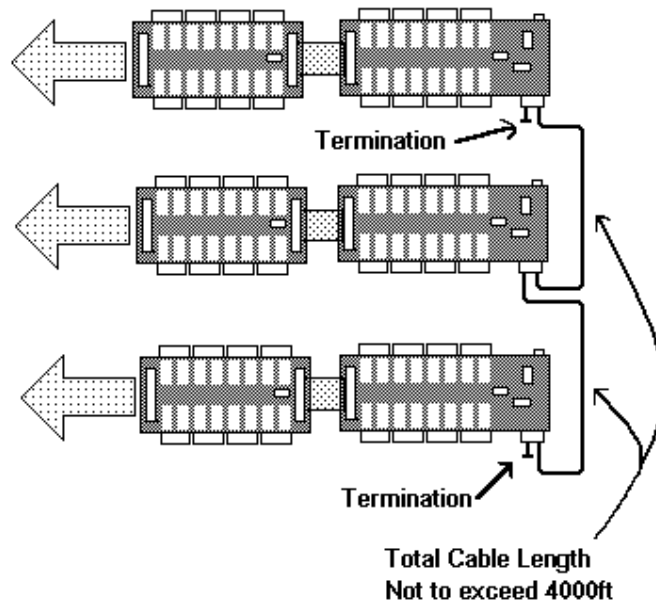

FIGURE 2.11 MAXIMUM DATASCAN NETWORK DISTANCE

## 2.2.13 RS232 Interface Cabling

Before a computer or display can communicate via the RS232 Interface, the correct Baud Rate has to be set up on the Measurement Processors Module Configuration DIP switch as shown below

The communication protocol used by Datascan is fixed as 8 bit data, 1 stop bit, no parity.

S1	S2	Baud Rate
Off	Off	19,200
On	Off	38,400
Off	On	4,800
On	On	9,600

### 2.2.13.1 Connecting to an IBM PC or Compatible

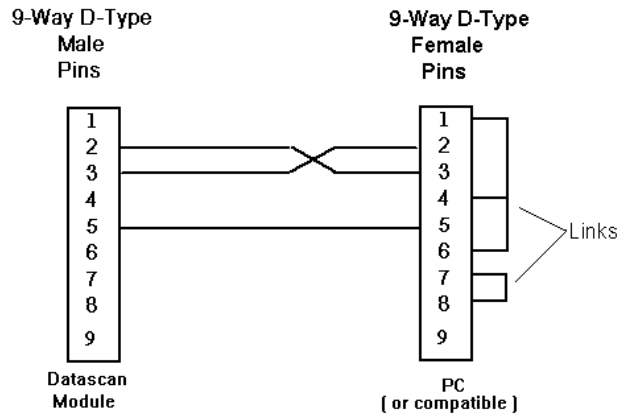

FIGURE 2.12 RS232 CONNECTION TO PC ( 9 PIN CONNECTOR).

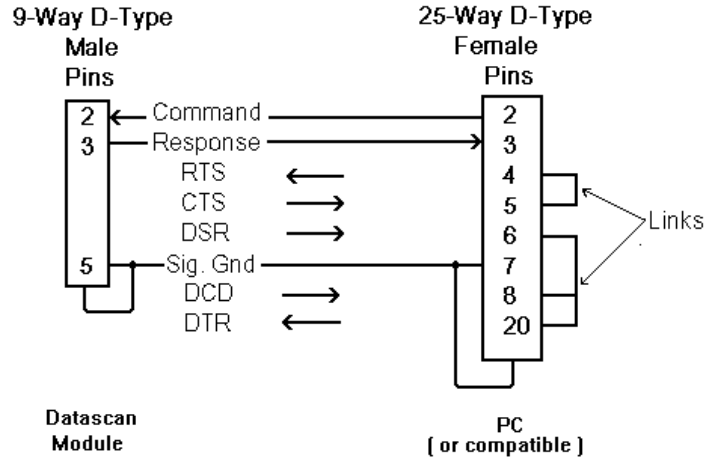

FIGURE 2.13 RS232 CONNECTION TO PC ( 25 PIN CONNECTOR)

### 2.2.13.2 Connecting to a Terminal (VDU)

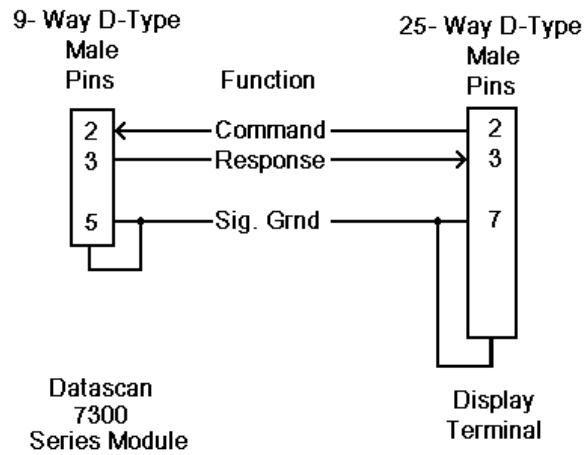

FIGURE 2.14 RS232 CONNECTION TO TERMINAL ( VDU )

### 2.2.14 Expansion Bus Cabling

Scanner modules are connected to the 7010 and 7300 series of measurement processors by 26-way ribbon cable connectors.

The total length of the Expansion Bus must be less than 10 metres (32 feet). See figure 2.13.

Scanner modules must NOT be attached to, or disconnected from the system whilst power is applied.

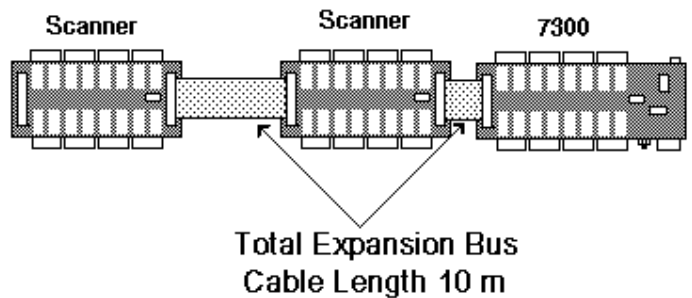

FIGURE 2.15 EXPANSION BUS CABLE LENGTH

### 2.2.15 I/O Cabling

Connections between sensor outputs and the Datascan Modules are made using plug in screw terminal blocks for ease and speed of installation, and for later possible re-configuration.

The general rule for I/O connection to the modules is to have the sensors (e.g. thermocouples) as near to their respective measurement modules as possible, taking into consideration the environmental limits of the Datascan units.

For details regarding the connection of the differing sensor types to specific Datascan modules refer to the relevant section identified in table 2.2.

## 2.2.16 Installation Notice for 7300 Processor Modules

Due to the nature of accurate temperature measurement it is important to take account of the operating environment of any sensitive temperature measuring device.

In order to ensure operation within the published temperature accuracies for the 7300 modules the following environment conditions should be met.

(1) The units should be mounted vertically ( i.e. with the Datascan label face vertical and the writing on it horizontal) in a draft free enclosure, away from any external heat sources.

(2) The units should be allowed to stabilise, in a powered condition for around 1 hour before accurate readings are taken.

These two recommendations do not effect either Voltage, 4-20mA and PT100 measurements.

Please note that the 7320, 7321 and 7327 modules can now be powered only from a 24V DC power supply.

**For information on sensor connections see section 6 of this manual.**

## 2.2.17 Installation and Use Recommendations

### Light industrial applications

To meet the requirements of BSEN 50081 & 2-1:1992 for light industrial use it is recommended, although not essential that multi-module systems be installed in a suitable metal enclosure & in most cases this will be found to be the most convenient method.

### Heavy industrial applications

To meet the heavy industrial immunity standard a metal enclosure is required to house all modules interconnected with parallel expansion cable.

In addition the earth connection of the supply cable to the 7981 power supply should be connected to the enclosure as close to the point of entry as possible. The screen of the RS485 interface cable should also be connected using screened cable and with the screen connected to the enclosure at the point of entry. The cables should then be threaded through ferrite sleeve cores before and after the case connection.

If isolation between these ports is required the connection of the screen to the enclosure can be made through 10nF capacitors mounted directly between DIN rail or other suitable terminal strips close to the point of exit. The cables should then be threaded through ferrite sleeve cores before and after the capacitor connection.

(Farnell part 106-364 is a suitable capacitor and 559-544 is a suitable sleeve.)

## **3. Datascan System Configuration**

---

### **3.1 Datascan System Layout Considerations**

The Datascan System can support up to 32 Measurement Processors, Gateway or Timer Counter modules connected to a RS485 Network. Each expandable Measurement Processor, 7010 or 7300 can support up to 256 channels via its scanner expansion bus. A maximum of 1000 channels can be supported over the entire RS485 Network.

The above limits are reduced when certain modules are incorporated in a Datascan System. The following sections detail the limitations of these modules.

#### **3.1.1 Using Digital Input Expansion Modules**

Volt free contacts can be powered from the 7031 and 7036 modules. If this feature is used then up to 100 channels can be energised from a single Measurement Processor. This limit does not apply to inputs that are externally energised.

#### **3.1.2 Using Analog Output Expansion Modules**

Due to the power requirements of the 7050 modules only 5 of them can be connected to a Measurement Processor.

If the module is being used as a set of 4 to 20mA sources, an external, isolated 24V DC supply must be connected (e.g. 7981), to the auxiliary 24V input connections on each scanner.

#### **3.1.3 Using Isolated Analog Input Modules**

##### **3.1.3.1 7026 Solid State Isolated Expansion Module**

Due to the higher power consumption of the 7026 modules a maximum of 10 can be connected to each measurement processor.

##### **3.1.3.2 7027 Reed Relay Isolated Expansion Modules**

To maintain the isolation specification only 8 7027 modules can be connected to a Measurement Processor, (7 to a 7327 module Processor).

---

## 3.2 Channel Address Configuration

Any input or output module connected to the Datascan Network must be allocated a channel base address which is set up using the tables in Section 8. Datascan modules have either 8 channels or 16 channels of I/O.

16 Channel modules (e.g., 7320, 7020, 7031 etc.) can be set to any 16-channel block within the 1 - 1000 range starting at a 16-channel boundary.

e.g. Ch1 - 16  
Ch33 - 48  
Ch 273 - 288

They **CANNOT** be set on an 8-channel boundary.

8 Channel Modules (e.g. 7321, 7021 etc.) can be set at any 8-channel boundary.

e.g. Ch 1 - 8  
Ch 9 - 16  
Ch 33 - 40  
Ch 281 - 288

**Note:**

**If any of the Datascan System set-up switches, including channel address switches are changed after power up they will have no effect until the power to the module is removed and then re-applied.**

### 3.2.1 7010 Measurement Processor

Providing the total number of channels supported by a single 7010 Measurement Processor module does not exceed 256 then the channel base address allocated to each scanner expansion modules does not have to be contiguous, they can be randomly selected blocks within the overall range.

For example a 7010 Module may have the following channels attached:

Ch 1- 64, Ch 113-136, Ch 449-496, Ch 705 - 736.

### 3.2.2 7200 Measurement Processors

On 7200 modules the channel address also determines the module's network address. The switch settings give a binary code representing 0 to 31. Switch 4 is the MSB, switch 8 the LSB (refer to Section 8.4 and 8.5).

### 3.2.3 7300 Analog Measurement Processors

Each 7300 Analog Measurement Processor can be set to allocate its onboard input channels to a base address within the 1 - 1000 channel range. Providing the total number of channels supported by a single 7300 series module does not exceed 256 then the channel base address allocated to adjacent scanner expansion modules does not have to be contiguous, they can be randomly selected blocks within the overall range.

For example a 7320 Module may have the following channels attached:

Ch 1- 64, Ch 113-136, Ch 449-496, Ch 705 - 736.

### 3.2.4 General Considerations

Care must be taken that no two modules, either 7200 series, 7300 series or scanner expansion modules share the same channel base address. All Datscan Modules, digital or analog must have unique channel number settings.

On systems with more than one measurement processor channel blocks can be randomly arranged on each local, 7200, 7010 and 7300 module and any scanner modules attached to the local host. Provided that:

1. Not more than 256 channels are connected to each 7300 or 7010 measurement processor. (See Section 3.1 for limitations).
2. No two modules anywhere on the system contain the same module channel base address.
3. The Measurement Processor and any Network Interface modules are given different network addresses (see Section 2.3)
4. 7200 series modules and 7041 timer counter module can only be set within the channel range 1 to 256.

### 3.2.5 Channel Address Set-up

Channels are configured on each module type by means of DIP switches. The location of the DIP switches are shown in Figures 2.1 to 2.7.

## 3.3 RS485 Network Configuration

If only one measurement processor is to be included in the Datscan System then the following section can be ignored.

Each Measurement Processor module or network interface module on a Datscan network must be allocated an individual network node address in order that software commands can be directed at specific modules (e.g. the

control of a Display Terminal connected to a remote 7010, 7200 or 7300 Measurement Processor) or 7011 Network Gateway module.

If there is no requirement to provide a particular network address on a 7010, 7011 or 7300 on the network, it is sufficient that different Network Switch selections are made at each node. The exact number of the node is not important in this instance.

When all modules on a Datascan Network are powered the successful operation of the Network is indicated by the illumination of the Network LED on each of the Measurement Processor and Network Interface Modules. If the LED fails to light on all modules then this indicates an installation or configuration error.

1. Check that module configuration switches are set correctly on all units.
2. Check if two or more modules have been set to the same network address.
3. Check that no two modules whether Measurement Processors or expansion scanner modules have the same channel base address set.
4. Check also the Network cabling for shorts and reverse connections. Also check that Network Terminators are correctly fitted.

**Note:**

**If any of the Datascan System set-up switches are changed after power up they will have no effect until the power to the module is removed and then re-applied.**

### 3.3.1 Network Switch Settings

For location of the Network Address configuration please refer to Figures XXX. Details of the network switch settings can be found in Table 8.3 in Section 10 of this Guide.

If network address 31 is selected on any module (Module Configuration Switches 4 to 8 all ON ) then the battery backup feature is disabled. This allows the internal database to be cleared of all previous data.

**Note:**

**The Network address must be different on each Measurement Processor on the network. The Network Address for the 7200 and 7041 modules also determine their channel address.**

## 4. Measurement Processors

### 4.1 7200 Measurement Processors (Non Expandable)

Each module in the 7200 range is completely self contained and has

1. An RS232 port to interface to host computer systems or local display terminals.
2. An RS485 Datascan network port for system expansion.
3. 8 or 16 input/output channels depending on the model.

The 7200 series does not have a local expansion port and is therefore used as a low cost collection unit used in locations where only a few channels are required.

Table 4.1 lists the range of 7200 Modules currently available.

Type No.	Channels	Sensors Supported
7220	16 (3 Pole)	DC Voltage, Thermocouples, and current (via suitable shunt).
7221	8 (6 Pole)	DC Voltage, Thermocouples, current (via suitable shunt), PRT's Resistance sensors and Strain Gauges
7250	8 input (2 pole)  8 outputs (2 pole) voltage or current	DC Voltage, Thermocouples, and current (via suitable shunt).  Voltage o/p -10 to +10 V. Current o/p 4-20mA

TABLE 4.1 7200 MODULES

## 4.2 7300 Measurement Processors (Expandable)

The Analog Measurement Processor range provides a cost effective means of connecting plant sensors to standard computers. The 7300 series modules provides in one package all the measurement processing, network handling, communication handling and scanner expansion bus capabilities as well as an integral analog scanner module.

The 7300 series modules can be used autonomously or alternatively as part of a total distributed network see figure 1.1. Each 7300 module can support up to 256 channels of local inputs or outputs using the unit's expansion bus. Alternatively it can be part of a distributed network up to 1000 channels.

7300 modules are directly compatible with all scanner units in the Datascan range as well as the earlier 7010 and 7200 series modules. Table 4.2 lists the range currently available.

Type No.	Channels	Sensors Supported
7320	16 ( 3 pole )	DC Voltage, Thermocouples and Current (via suitable shunt )
7321	8 ( 6 pole)	DC voltage, Thermocouples, Current (via suitable shunt), PRT's, Resistance sensors and Strain Gauges
7327	16 (3 pole) Isolated	DC Voltage, Thermocouples and Current (via suitable shunt )

**TABLE 4.2 7300 ANALOG MEASUREMENT PROCESSOR MODULES AVAILABLE**

### Temperature Accuracy 7320, 7321 and 7327 Measurement Processors.

In order to ensure operation within the published specification 7320, 7321 and 7327 modules the following environmental conditions should be met.

1. The units must be mounted **vertically**. (i.e. the Datascan label face vertical and the writing horizontal) in a draft free enclosure away from any external heat sources.
2. The units must be allowed to **stabilise**, in a powered condition for **1 hour** before accurate readings are taken.

These recommendations do not affect Voltage, 4-20mA , strain and PT100 readings.

## 5. Scanner Expansion Modules

### 5.1 Analog Scanner Expansion Modules

Analog Scanner Expansion Modules monitor voltages, currents and the output of analog sensors, to provide signal conditioning for the 7010 Measurement Module and channel expansion for the 7300 Analog Measurement Processor Modules via their expansion bus.

Table 5.1 lists the range of Analog Scanner Modules currently available

Type No.	Channels	Sensors Supported
7020	16 (3 pole)	DC Voltages, Thermocouples, and Current (via suitable shunt)
7021	8 (6 pole)	DC Voltages, Thermocouples, Current (via suitable shunt) PRTs, Resistance & Strain Gauges
7026	8 (4 pole) Isolated Inputs	DC Voltages, Thermocouples, and Current (via suitable shunt)
7027	16 (3 Pole) Reed Relay Isolated Inputs	DC Voltages, Thermocouples, and Current (via suitable shunt)
7050	8 (2 Pole) i/p  8 Voltage or Current o/p	DC Voltages, Thermocouples, and Current (via suitable shunt)  Voltage o/p -10 to +10V Current o/p 4-20mA.

TABLE 5.1 ANALOG SCANNER MODULES AVAILABLE

## 5.2 Digital Scanner Expansion Modules

Digital Scanner Modules are used to either monitor digital signals and low frequency counting inputs or provide digital output command signals.

The digital input and output signals are fed to and received from a Measurement Processor via its Expansion Bus and although their parameters and uses vary according to the particular Scanner Module, they can generally be regarded as follows :

Table 5.2 lists the range of Digital Scanner Modules currently available.

Module Number	Channels	Channel Types
7031	16 inputs	AC/DC input, Volt-Free Contact and low frequency counter
7035	16 Outputs	DC Outputs 0.5A
7036	8 Inputs 8 Outputs	Inputs: DC Inputs Volt-Free Contact and low frequency counter Outputs: DC 0.5A
7041	8 Inputs 8 Inputs	DC Input - Status Counting to 3.5Khz Period Measurement to 128 aS Frequency to 3.5Khz Event Timing Status Input Counting to 10 Hz

TABLE 5.2 DIGITAL SCANNER MODULES AVAILABLE

### 5.2.1 Digital Input Channels

#### 5.2.1.1 Input Connections

Inputs are connected to the digital scanner modules using the detachable screw terminal connectors.

Inputs can be DC or AC.

For an input to be "ON" the voltage applied must be greater than 4V DC or AC RMS. To be "OFF" the applied voltage must be less than 1V DC or AC PEAK.

Some typical connection circuits are shown in Section 6.3

### 5.2.1.2 Volt Free Contact Energisation

For convenience, 'volt free' contacts can be energised using an isolated power supply within each module with input capability. The output is  $5V \pm 0.5V$  and it can supply sufficient current to energise 16 input circuits.

Six pairs of terminals are provided to ease termination problems. These are 'commoned', they are not six separate supplies.

**Note:**

**Power for this supply is taken from the Scanner Expansion Bus. This limits the number of channels, which can be energised on each 7010 or 7300 to 100. If you require more than 100 channels to be energised, a separate power supply must be used.**

## 5.2.2 Digital Output Channels

### 5.2.2.1 Output Connections

Digital outputs are connected using the detachable screw terminal connectors.

The equivalent circuit for each output is shown in Section 6.4.

The switching element is a MOSFET. A zener diode protects the output switch from over voltages when driving inductive loads. The power dissipation in this clamping circuit must be limited to 0.5W.

The output channels are each capable of switching 0.5A in the ON state, or blocking up to 32V in the OFF state. Outputs are zener protected to enable them to drive inductive loads directly.

Each output is individually transformer isolated from ground and from the other channels. It is therefore unnecessary to worry about the wiring of other channels when connecting to an output channel. A number of possible connection circuits are shown in Section 6.4.

## 5.3 Counter Timer Module 7041

Although the 7041 is strictly speaking an expansion module it has on board its own measurement processor. Although it has its own measurement processor it does not have any RS232 communication ability. It must therefore connect to a Measurement Processor, via the RS485 Datascan network, to be able to communicate with the outside world.

The 7041 Counter Timer is a 16-channel module containing 8 Counter Timer channels (Channels 1 to 8) and 8 digital input channels (Channels 9 - 16).

A current limited 5V DC power supply is provided to energise volt free contacts.

Battery supported memory holds the entire system configuration. Once the module has been programmed, channel types, set-ups, labels etc. are not lost when the unit is powered down.

---

## 6. Sensor Connections

---

The following section details the sensor input and output connections to the Datascan Modules.

When connecting sensors minimise interference on the inputs by:

1. If screened cable is used, connect the screen to the guard terminal.
2. Keeping cable runs as short as possible.
3. Use screened cable for minimum noise.
4. Avoid running low-level signal cables next to power cables.
5. Use 16-bit A/D mode for maximum noise rejection.
6. Avoid unwanted thermocouple junctions by keeping the number of connectors to a minimum and avoid temperature gradients.
7. The potential generated by a thermocouple depends on the temperature gradient along its length. Make sure that the temperature difference is along the thermocouple and NOT the compensating cable.
8. Isothermal bars within the modules 'thermally connect' all channels on each side of the unit (i.e. channels 1-8 and channels 9 to 16). The temperature of these bars is measured and can be used as the cold junction reference. If this facility is being used, take care to avoid unnecessary temperature gradients around the modules.

### **Temperature Accuracy 7320, 7321 and 7327 Measurement Processors.**

In order to ensure operation within the published specification 7320, 7321 and 7327 modules the following environmental conditions should be met.

1. The units must be mounted **vertically**. (i.e. the Datascan label face vertical and the writing horizontal) in a draft free enclosure away from any external heat sources.
2. The units must be allowed to **stabilise**, in a powered condition for **1 hour** before accurate readings are taken.

These recommendations do not affect Voltage, 4-20mA, strain and PT100 readings

## 6.1 Common Mode Range (Non Isolated Modules)

The module common mode rejection circuit is shown at the end of each of the sections in 6.2. Both the H & L inputs are high impedance. Therefore, the 'common mode' potential must be defined. This is done by ensuring that Low and the Guard terminal are connected at some point.

The Datascan system as a whole is isolated from earth by the power supply and interface circuits within the Measurement Processor module. It is therefore possible for the whole system to have common mode potentials up to 200V away from earth provided that all inputs are at approximately the same common mode potential. This limit is reduced to 100V if any digital module (7031, 7035, 7036 or 7041) is present on the system.

The inputs of the 7020, 7021, 7050, 7220, 7221, 7250, 7320 and 7321 modules are not isolated. They are multiplexed using semi-conductor switches, which limits the inter-channel common mode range. This limit applies across the whole system, not just to one module.

Protection circuits prevent damage if overloads of up to 30V are applied.

To ensure you do not exceed the common mode range or overload any input:

1. No input must be more than 200V DC or AC peak away from earth.
2. The maximum potential between any guard terminal and any other terminal on this or any other module connected to a local measurement processor must not exceed 12V.
3. The maximum input signal between the H and L terminals must not exceed 12V.

**Note:**

**An overload on one channel may affect some or all the other channels on the system.**

## 6.2 Analog Inputs

The following tables identify which of the following sections should be used for each Datascan Module type.

Module	Number of Poles	Isolation		Overload Protection	Sensor Input Wiring Section	Sensor Output Wiring Section
		Chan to Chan	Chan to Ground			
7020	3	±12V	±200V	±30 V	6.2.2	
7021	6	±12V	±200V	±30 V	6.2.4	
7026	4	±1000V	±1000V	± 200 V	6.2.3	
7027	3	±200V	±200V	± 100 V	6.2.2	
7050	2	±12V	±200V	± 30 V	6.2.1	6.5
7220	3	±12V	±200V	± 30 V	6.2.2	
7221	6	±12V	±200V	± 30 V	6.2.4	
7250	2	±12V	±200V	± 30 V	6.2.1	6.5
7320	3	±12V	±200V	± 30 V	6.2.2	
7321	6	±12V	±200V	± 30 V	6.2.4	
7327	3	±200V	±200V	±100V	6.2.2	

**TABLE 6.1 ANALOG INPUT MODULES**

## 6.2.1 2 Pole Inputs

This section details input connections to channels 1-8 of the 7050 scanner module and 7250 Measurement Processor modules

### 6.2.1.1 Voltage Input Connections (Channels 1-8)

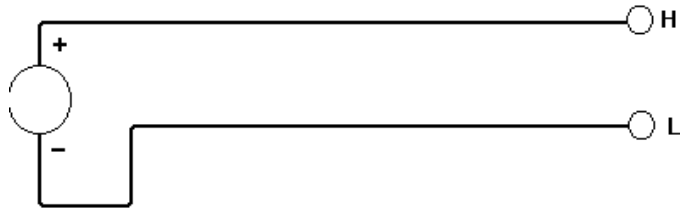
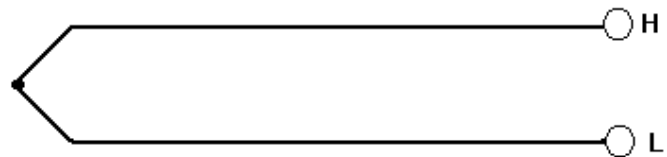

FIGURE 6.1 2 POLE VOLTAGE CONNECTION

### 6.2.1.2 Thermocouple Input Connection.

#### Direct Connection



#### Using 2 Core Extension Cable

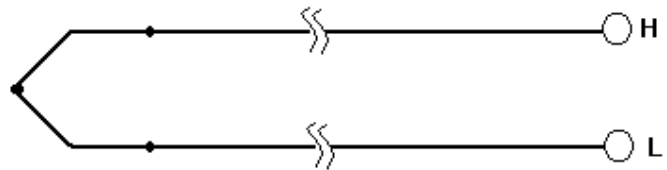

#### Using Screened Compensation Cable

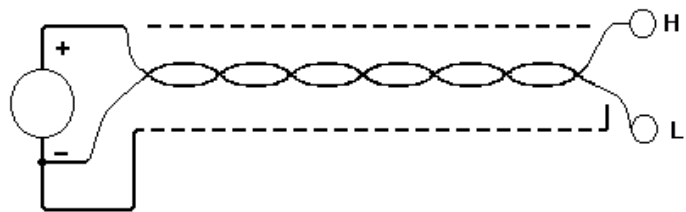

FIGURE 6.2 2 POLE THERMOCOUPLE CONNECTIONS

### 6.2.1.3 Current Source Connection

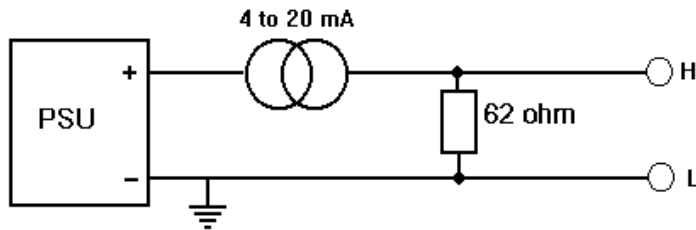

FIGURE 6.3 2 POLE CURRENT SOURCE CONNECTION

**Notes:**

1. If the power source is earthed, the current source should be connected as shown above.
2. If the power source is isolated, the transducer can be placed in either the high (H) or low (L) lead.
3. A 7250 & 7050 can be used to measure current if an external resistor is fitted as shown above. The tolerance of this resistor determines the accuracy of the current measurement. The specification assumes a 0.1% or better resistor.

### 6.2.1.4 Common Mode Range

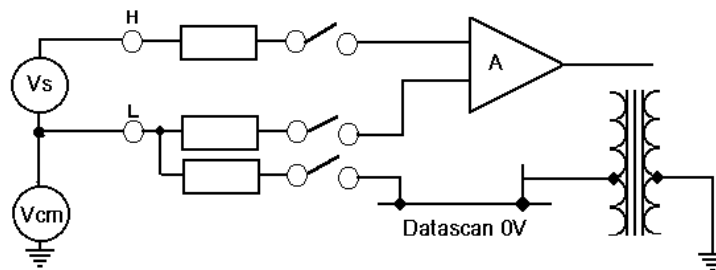

FIGURE 6.4 COMMON MODE SIGNAL REJECTION ( 2 POLE)

## 6.2.2 3 Pole Inputs

This section details the input connections for all 3 pole modules including: 7020, 7027, 7320 and 7327.

### 6.2.2.1 Voltage Input Connection

Voltage input range is bi-polar (-10V to +10V).

#### Connecting a Voltage source

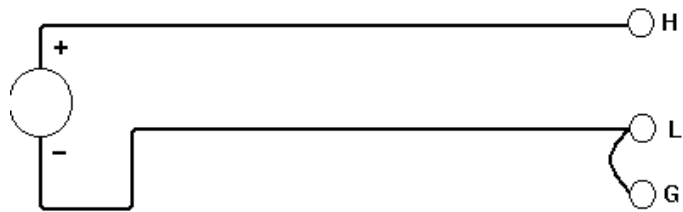

#### Connecting an isolated voltage source using screened cable.

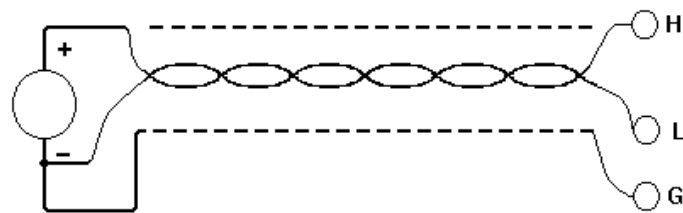
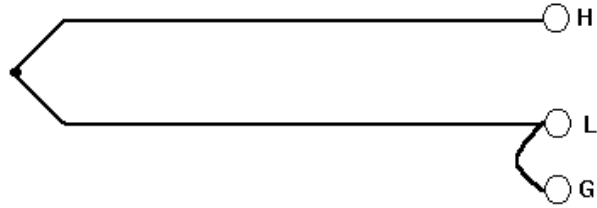

FIGURE 6.5 3-POLE VOLTAGE CONNECTIONS

### 6.2.2.2 Thermocouple Input Connection

#### Direct



#### Using 2 core compensating cable

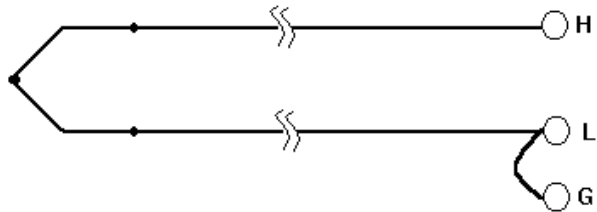

#### Using screened compensating cable

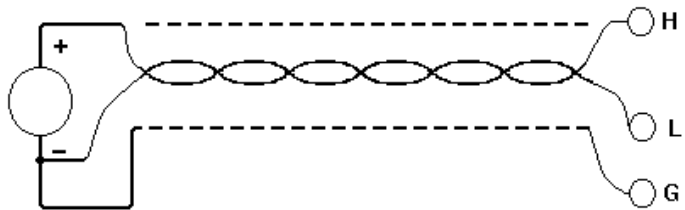

FIGURE 6.6 3-POLE THERMOCOUPLE CONNECTIONS

### 6.2.2.3 Current Source Connection

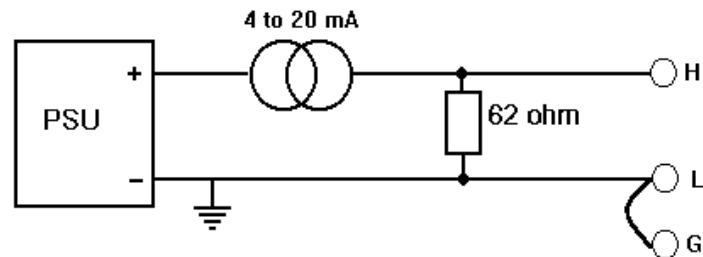

FIGURE 6.7 3-POLE CURRENT CONNECTION

**Notes:**

1. If the power source is earthed, the current source should be connected as shown in Figure 6.7.
2. If the power source is isolated, the transducer can be placed in either the high (H) or low (L) lead.
3. An analog module can be used to measure current if an external resistor is fitted as shown in Figure 6.7. The tolerance of this resistor determines the accuracy of the current measurement. The specification assumes a 0.1% or better resistor.
4. The guard terminal (G) should be linked to the low terminal (L).

### 6.2.2.4 Common Mode Range

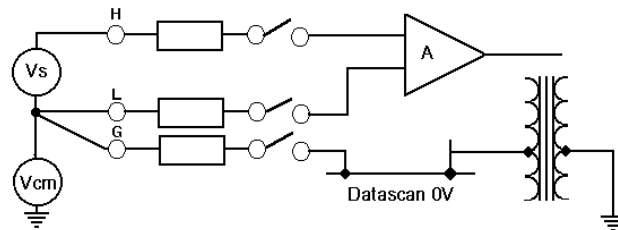

FIGURE 6.8 3-POLE COMMON MODE SIGNAL REJECTION CIRCUIT

**Note:**

Both H and L are high impedance. Therefore the 'common mode' potential must be defined. This is done by ensuring that the L and G terminals are connected at some point.

## 6.2.3 4 Pole Inputs (Isolated)

This section deals with inputs for the 7026 solid-state isolated module.

Signal wiring is connected to the 7026 module using detachable screw connectors. The wiring details for each sensor type supported are shown in the following sections.

### 6.2.3.1 Voltage Input Connections

#### 0-150mV Input Signals

For input signals in the range 0 to 150 mV, the input is applied across H1 and H2/L1, L2 and S are left open circuit.

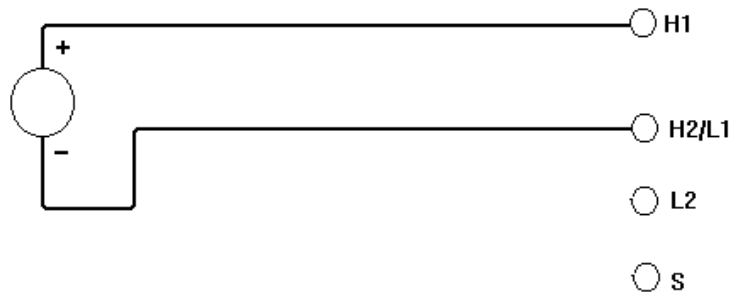

#### 0-10V Input Signals

For input signals in the range 0 to 10 volts, the input is applied across H2/L1 and L2, H1 and S must be shorted.

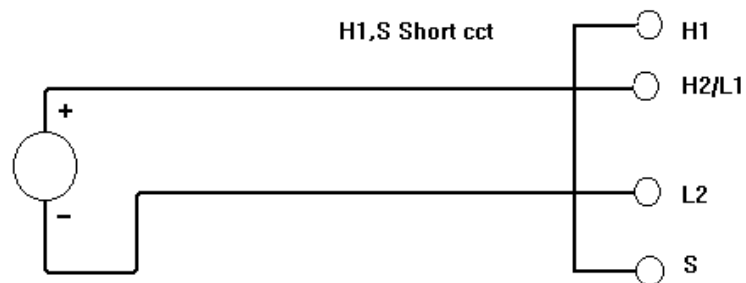

FIGURE 6.9 7026 VOLTAGE CONNECTIONS

### 6.2.3.2 Additional earth terminal

Provision is made on each module to allow the metal case to be earthed.

It is important that all modules are earthed to prevent hazards under fault conditions.

A second insulated earth terminal has been provided on the 7026 module to connect the circuitry's 0V to a safety EARTH to provide further protection under fault conditions. This second earth terminal must be independently connected to EARTH to prevent hazards under fault conditions. Do not link this terminal directly to the case earth stud.

During the event of a fault condition occurring, any HIGH voltages that may be present should be isolated from the system prior to any maintenance to any part of the Datascan installation.

Despite the inputs being isolated the equipment is not suitable for connection to MAINS or any other HIGH voltage supplies.

### 6.2.3.3 Thermocouple Input Connections

#### Direct Thermocouple Connection

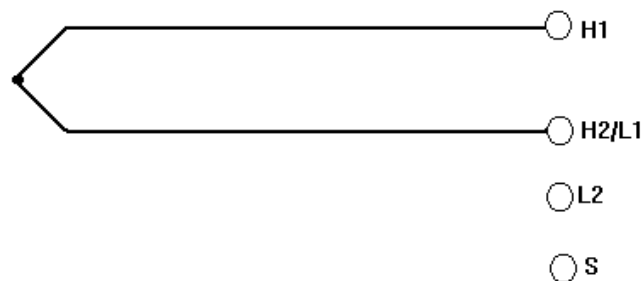

Using 2 core compensating cable

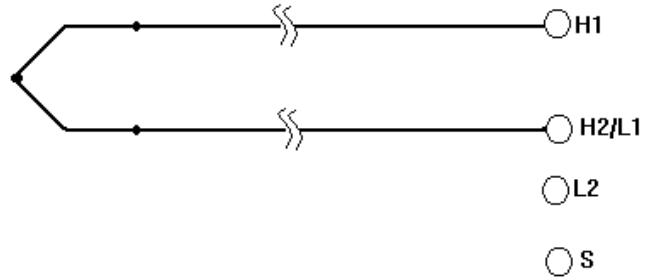

Using Screened Compensating cable

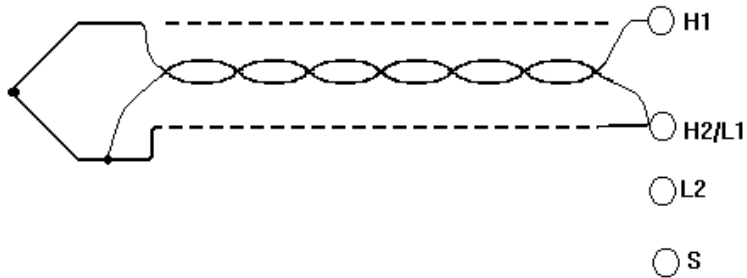

FIGURE 6.10 7026 THERMOCOUPLE CONNECTIONS

6.2.3.4 Current Source Connection

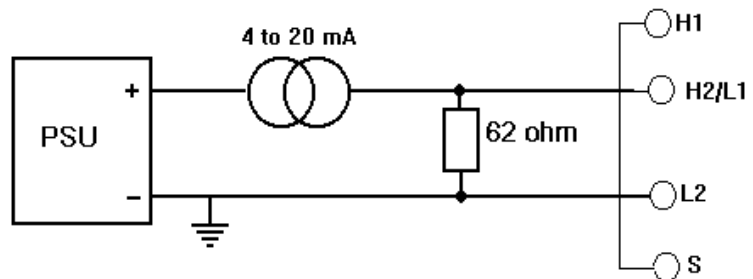

FIGURE 6.11 7026 CURRENT SOURCE CONNECTION

**Note:**  
The 7026 measures current by measuring the voltage developed in an external 62 Ohm resistor.

## 6.2.4 6 Pole Inputs

This section deals with inputs for the Datascan Modules with on board energisation for strain gauges, PRT's and resistance sensors. The modules include 7021, 7221 and 7321.

### 6.2.4.1 Voltage Input Connection

Voltage input range is bi-polar (-10V to +10V).

#### Voltage Source

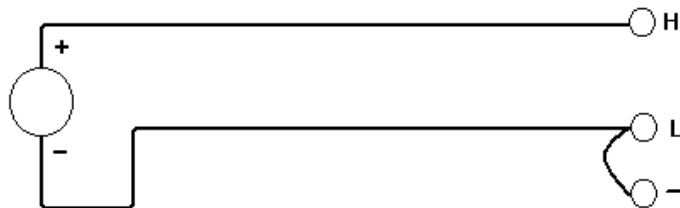

#### Isolated Voltage Source Using Screened Cable

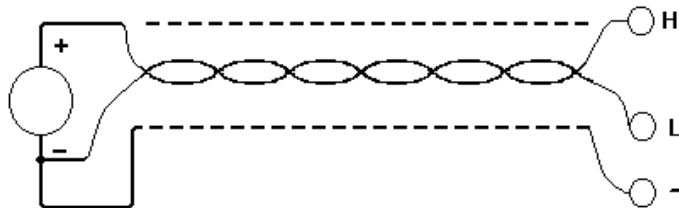
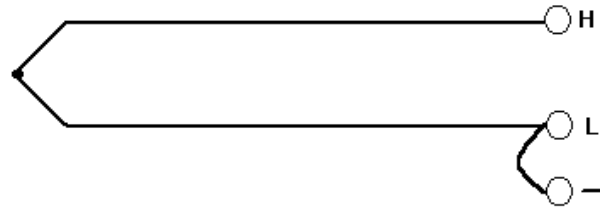

FIGURE 6.12 6-POLE VOLTAGE CONNECTIONS

### 6.2.4.2 Thermocouple Input Connection

Direct Connection



Using 2 core compensating cable

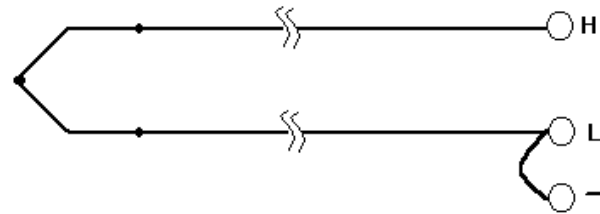

Using Screened compensating cable

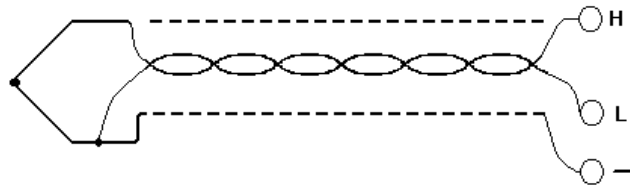

FIGURE 6.13 6-POLE THERMOCOUPLE CONNECTIONS

### 6.2.4.3 Current Source Connection

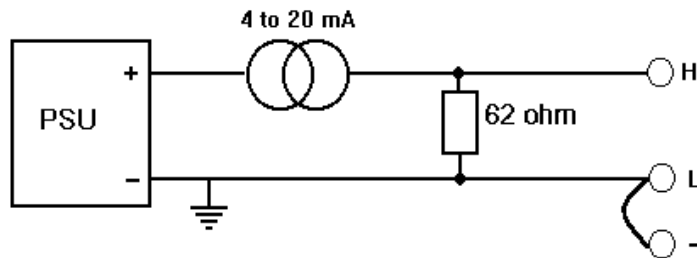

FIGURE 6.14 6-POLE CURRENT SOURCE CONNECTION.

**Notes:**

1. If the power source is earthed, the current source should be connected as shown in Figure 6.14.
2. If the power source is isolated, the transducer can be placed in either the high (H) or low (L) lead.
3. A 7021 / 7221 / 7321 module can be used to measure current if an external 62Ω resistor is fitted as shown in Figure 6.14. The tolerance of this resistor determines the accuracy of the current measurement. The specification assumes a 0.1% or better resistor.
4. The guard terminal (—) should be linked to the low terminal (L).

#### 6.2.4.4 Connecting a 4-Wire PRT or Resistance Device

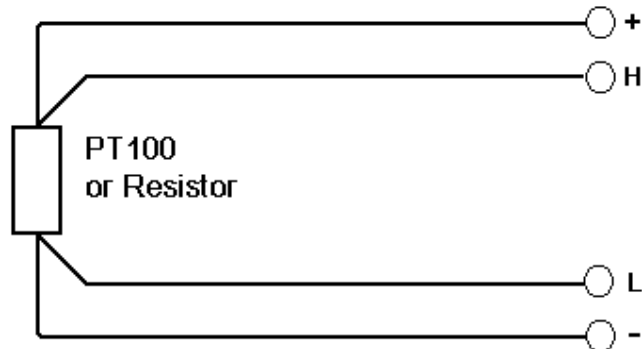

FIGURE 6.15 4-WIRE PRT CONNECTION.

**Notes:**

1. S+ S- terminals are not connected.
2. If screened cable is used, connect the screen to the (-) terminal.
3. The energisation source used is 0.75mA. This is only present whilst the channel is being measured, so self-heating effects are negligible.
4. The maximum measurable resistance is approximately 10K $\Omega$ .
5. The (L) to (-) connection should be as short as possible.
6. There will be a constant error due to unbalanced lead impedance. This can be calibrated out with the 'CB' command.

### 6.2.4.5 Strain Gauge Connections

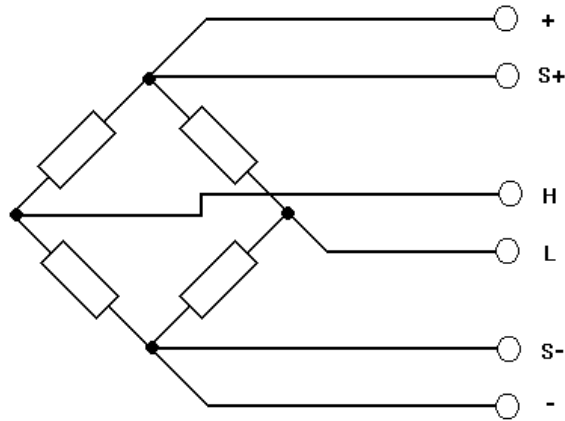

FIGURE 6.16 FULL BRIDGE STRAIN CONNECTION.

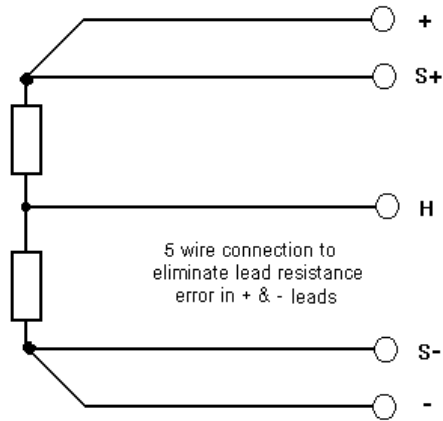

FIGURE 6.17 5-WIRE HALF BRIDGE STRAIN CONNECTION.

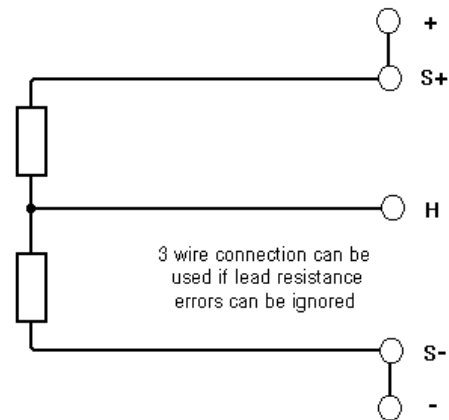

FIGURE 6.18 3-WIRE HALF BRIDGE CONFIGURATION.

**Notes:**

1. The bridge completion resistors are supplied within the Datascan unit.
2. The 3 wire connection will lead to calibration errors if long cable runs are used. The 5 wire scheme eliminates these errors.
3. Bridge is voltage energised at 1.8V therefore no changes required for different gauge resistance's.
4. Calculations assume gauge factor 1 & 1 active arm in the bridge. The scale and Offset facility should be used to correct for different gauge factors and more active arms.

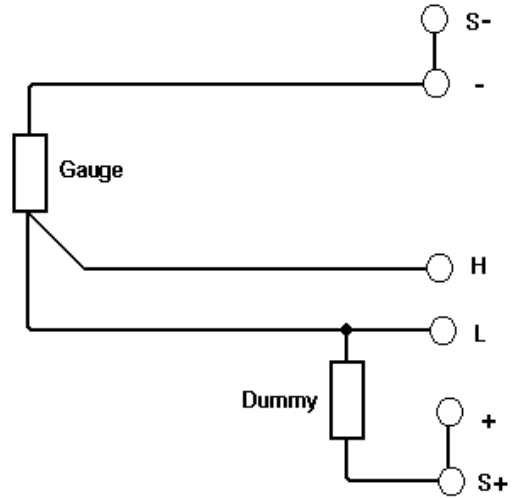

FIGURE 6.19 3-WIRE QUARTER BRIDGE STRAIN CONNECTION

- Notes:**
1. A 1/2 bridge completion circuit is provided within the Datascan unit. You must supply both the dummy and the gauge.

### 6.2.4.6 Common Mode Range

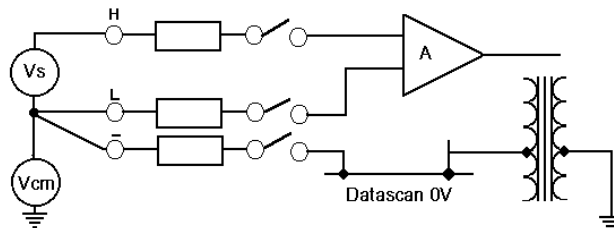

FIGURE 6.20 6-POLE COMMON MODE REJECTION CIRCUIT

**Note:**

Both H and L are high impedance. Therefore the 'common mode' potential must be defined. This is done by ensuring that the L and - terminals are connected at some point.

## 6.3 Digital Inputs

This section details the input connections for the range of digital input modules that include 7031, 7041 and channels 1 to 8 of 7036 and 7236.

Inputs are connected to the module using the detachable screw terminal connectors.

For an input to be "ON" the voltage applied must be greater than 4V DC or AC RMS. To be "OFF" the applied voltage must be less than 1V DC or AC PEAK.

Channels are individually isolated to 250 V RMS (354V DC) channel to channel and channel to ground.

A current limited 5V DC power supply is provided to energise volt free contacts. Six pairs of terminals are provided to ease termination problems. These are 'commoned', they are not six separate supplies.

Some typical connection circuits are shown in the following figures

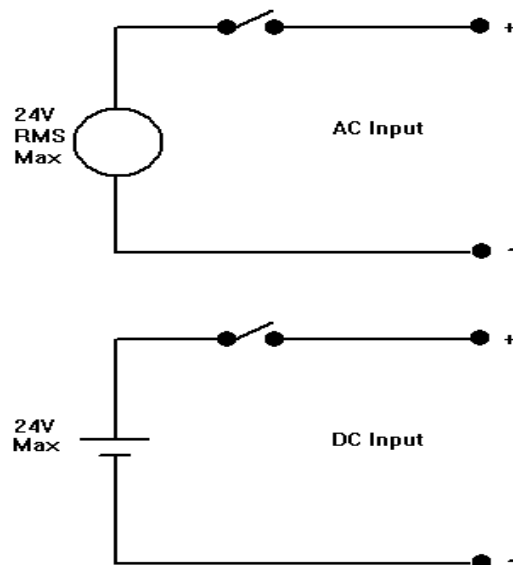

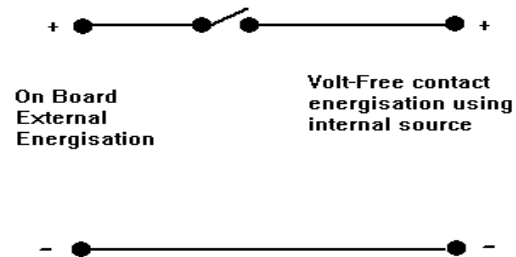

FIGURE 6.21 DIGITAL INPUT CONNECTIONS

### 6.3.1 Volt Free Contact Energisation

For convenience, 'volt free' contacts can be energised using an isolated power supply within each module. The output is  $5V \pm 0.5$  and it can supply sufficient current to energise 16 input circuits.

**Note:**

Power for this supply is taken from the Scanner Expansion Bus. This limits the number of channels which can be energised on each 7010 or 7300 to 100. If you require more than 100 channels to be energised, a separate power supply must be used.

Six pairs of terminals are provided to ease termination problems. These are 'commoned', they are not six separate supplies.

### 6.3.2 Overload Protection

Positive temperature coefficient thermistors are used to prevent damage under overload conditions up to 240V DC or AC RMS.

These voltages must only be present under fault conditions. Other channels on the module may be affected if any channels are overloaded.

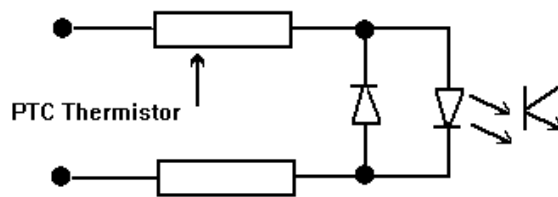

FIGURE 6.22 DIGITAL INPUT OVERLOAD CIRCUIT.

## 6.4 Digital Outputs

Digital outputs are available on the 7035, 7036 and 7236 Datascan Modules.

The outputs are connected using the detachable screw terminal connectors.

The equivalent circuit for each output is shown in Figure 6.32.

The switching element is a MOSFET. The zener diode protects the output switch from over voltages when driving inductive loads. The power dissipation in this clamping circuit must be limited to 0.5W.

Each output is individually isolated from ground and from the other channels. It is therefore unnecessary to worry about the wiring of other channels when connecting to an output channel.

A number of possible connection circuits are shown in Figure 6.33.

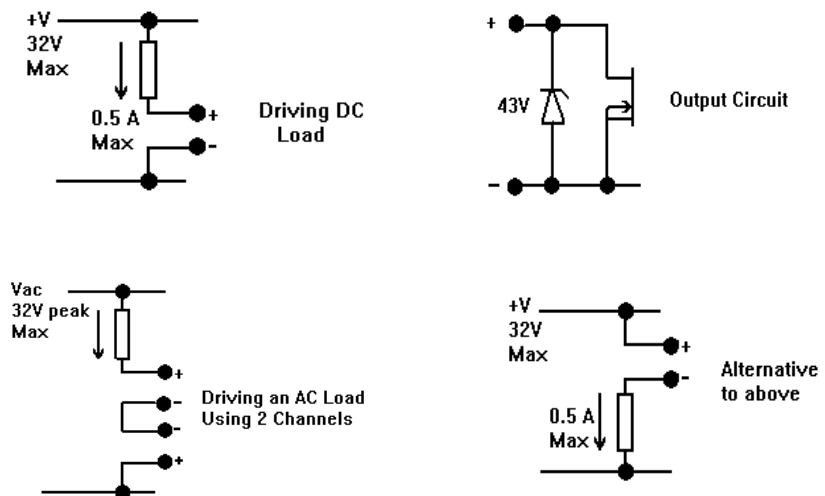

FIGURE 6.23 DIGITAL OUTPUT EQUIVALENT CIRCUIT.

## 6.5 Analog Outputs

Analog outputs are available on the 7050 and 7250 Datascan modules.

The voltage output can be set between -10V and +10V using suitable software commands. Up to 5mA can be drawn from each channel.

### 6.5.1 Voltage Outputs



FIGURE 6.24 VOLTAGE OUTPUT CONNECTIONS

The current terminal (I) to be left open circuit. The output is not isolated. It will be referenced to the ground of the driving Measurement Module

### 6.5.2 Current Outputs

Each channel has a current output which can be set from 4 to 20mA.

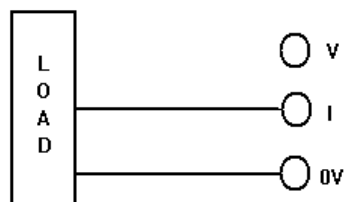

FIGURE 6.25 CURRENT OUTPUT CONNECTIONS

The Voltage Terminal (V) to be left open circuit.

**Note**

Current outputs require a 24VDC supply to be connected to the auxiliary 24V input on the 7050 module.

## 7. Network Gateway Modules

### 7.1 7011 Network Gateway Module

The 7011 Network Interface provides a low cost means of accessing the data on a Datascan network where there is no 7010, 7200 or 7300 module nearby. It has 2 communications ports, an isolated RS232 port for communicating with host computers, and an isolated RS485 Datascan network port. A typical installation using a 7011 module is shown below.

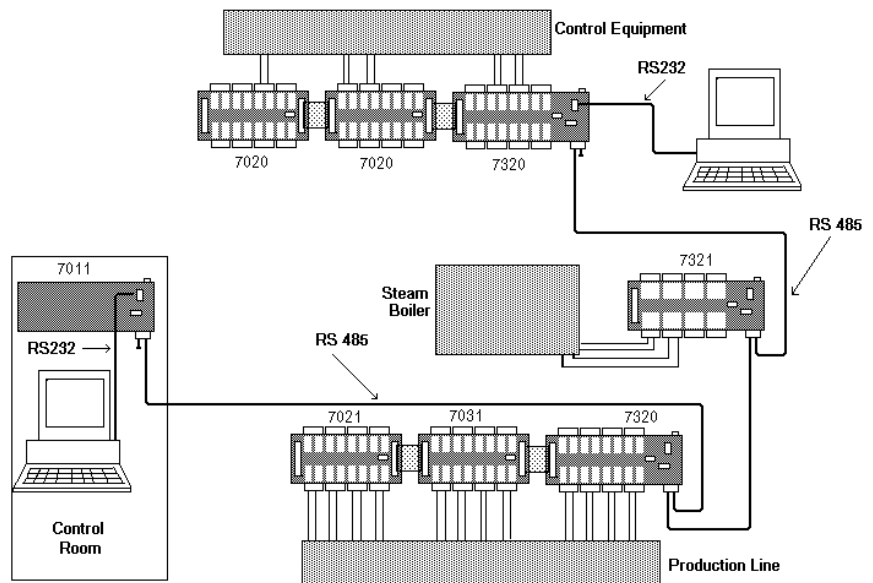

FIGURE 7.1 7011 IN TYPICAL DATASCAN INSTALLATION

## 7.2 DATASCAN 7011-M Modbus™ Interface

The 7011-M is a Modbus™ protocol converter for the Datascan System. The module interfaces a Modbus™ ASCII protocol master for configuration, reading and the writing of channels on the Datascan System. This allows any package with the above protocol support to utilise the superior channel acquisition, linearisation and networking capabilities of Datascan. The Datascan Technical Reference Manual should be consulted for information on this module.

## 8. Channel Address Switch Tables

The following Channel Address tables should be used to configure the Channel Address DIP Switches on Datascan Modules. The table below defines which table should be used for which module.

Module	Table
7020	8.1
7021	8.2
7026	8.2
7027	8.1
7031	8.1
7035	8.1
7036	8.1
7041	8.4

Module	Table
7050	8.1
7220	8.4
7221	8.5
7250	8.4
7320	8.1
7321	8.2
7327	8.1

**TABLE 8.0 CHANNEL ADDRESS TABLE LOCATOR**

Table 8.3 should be used to configure the Network Address DIP Switches on the 7010, 7011, 7320, 7321 and 7327 modules.

**Note:**

Care should be taken when configuring the switches on networks containing modules 7041, 7220, 7221, 7236 and 7250. The network node address on any other Measurement Processor or Network Interface module should not conflict with the resultant network address when setting the channel addresses on the aforementioned modules.

S1	S2	S3	S4	S5	S6	S7*	Channel Range
Off	Off	Off	Off	Off	Off	Off	1 - 16
Off	Off	Off	Off	Off	On	Off	17 - 32
Off	Off	Off	Off	On	Off	Off	33 - 48
Off	Off	Off	Off	On	On	Off	49 - 64
Off	Off	Off	On	Off	Off	Off	65 - 80
Off	Off	Off	On	Off	On	Off	81 - 96
Off	Off	Off	On	On	Off	Off	97 - 112
Off	Off	Off	On	On	On	Off	113 - 128
Off	Off	On	Off	Off	Off	Off	129 - 144
Off	Off	On	Off	Off	On	Off	145 - 160
Off	Off	On	Off	On	Off	Off	160 - 176
Off	Off	On	Off	On	On	Off	177 - 192
Off	Off	On	On	Off	Off	Off	193 - 208
Off	Off	On	On	Off	On	Off	209 - 224
Off	Off	On	On	On	Off	Off	225 - 240
Off	Off	On	On	On	On	Off	241 - 256
Off	On	Off	Off	Off	Off	Off	257 - 272
Off	On	Off	Off	Off	On	Off	273 - 288
Off	On	Off	Off	On	Off	Off	289 - 304
Off	On	Off	Off	On	On	Off	305 - 320
Off	On	Off	On	Off	Off	Off	321 - 336
Off	On	Off	On	Off	On	Off	337 - 352
Off	On	Off	On	On	Off	Off	353 - 368
Off	On	Off	On	On	On	Off	369 - 384
Off	On	On	Off	Off	Off	Off	385 - 400
Off	On	On	Off	Off	On	Off	401 - 416
Off	On	On	Off	On	Off	Off	417 - 432
Off	On	On	Off	On	On	Off	433 - 448
Off	On	On	On	Off	Off	Off	449 - 464
Off	On	On	On	Off	On	Off	465 - 480
Off	On	On	On	On	Off	Off	481 - 496
Off	On	On	On	On	On	Off	497 - 512

**TABLE 8.1A 16 CHANNEL ADDRESS SWITCH SETTINGS (1-512)**

\* Switch 7 may not be fitted on some modules.

This table used to configure the Channel Address switches on the 7020, 7027, 7031, 7035, 7036 7050 and 7320 modules.

**Note:** If any Datascan set-up switches are changed after power up they will have no effect until the power to the module is removed and then re-applied.

S1	S2	S3	S4	S5	S6	S7*	Channel Range
On	Off	Off	Off	Off	Off	Off	513-528
On	Off	Off	Off	Off	On	Off	529-544
On	Off	Off	Off	On	Off	Off	545-560
On	Off	Off	Off	On	On	Off	561-576
On	Off	Off	On	Off	Off	Off	577-592
On	Off	Off	On	Off	On	Off	593-608
On	Off	Off	On	On	Off	Off	609-624
On	Off	Off	On	On	On	Off	625-640
On	Off	On	Off	Off	Off	Off	641-656
On	Off	On	Off	Off	On	Off	657-672
On	Off	On	Off	On	Off	Off	673-688
On	Off	On	Off	On	On	Off	689-704
On	Off	On	On	Off	Off	Off	705-720
On	Off	On	On	Off	On	Off	721-736
On	Off	On	On	On	Off	Off	737-752
On	Off	On	On	On	On	Off	753-768
On	On	Off	Off	Off	Off	Off	769-784
On	On	Off	Off	Off	On	Off	785-800
On	On	Off	Off	On	Off	Off	801-816
On	On	Off	Off	On	On	Off	817-832
On	On	Off	On	Off	Off	Off	833-848
On	On	Off	On	Off	On	Off	849-864
On	On	Off	On	On	Off	Off	865-880
On	On	Off	On	On	On	Off	881-896
On	On	On	Off	Off	Off	Off	897-912
On	On	On	Off	Off	On	Off	913-928
On	On	On	Off	On	Off	Off	929-944
On	On	On	Off	On	On	Off	945-960
On	On	On	On	Off	Off	Off	961-976
On	On	On	On	On	On	Off	977-992

TABLE 8.1B 16 CHANNEL ADDRESS SWITCH SETTINGS (513-1000)

\* Switch 7 may not be fitted on some modules.

This table used to configure the Channel Address switches on the 7020, 7027, 7031, 7035, 7036 7050 and 7320 modules.

**Note:** If any Datascan set-up switches are changed after power up they will have no effect until the power to the module is removed and then re-applied.

S1	S2	S3	S4	S5	S6	S7	Channel Range
Off	Off	Off	Off	Off	Off	Off	1-8
Off	Off	Off	Off	Off	Off	On	9-16
Off	Off	Off	Off	Off	On	Off	17-24
Off	Off	Off	Off	Off	On	On	25-32
Off	Off	Off	Off	On	Off	Off	33-40
Off	Off	Off	Off	On	Off	On	41-48
Off	Off	Off	Off	On	On	Off	49-56
Off	Off	Off	Off	On	On	On	57-64
Off	Off	Off	On	Off	Off	Off	65-72
Off	Off	Off	On	Off	Off	On	73-80
Off	Off	Off	On	Off	On	Off	81-88
Off	Off	Off	On	Off	On	On	89-96
Off	Off	Off	On	On	Off	Off	97-104
Off	Off	Off	On	On	Off	On	105-112
Off	Off	Off	On	On	On	Off	113-120
Off	Off	Off	On	On	On	On	121-128
Off	Off	On	Off	Off	Off	Off	129-136
Off	Off	On	Off	Off	Off	On	137-144
Off	Off	On	Off	Off	On	Off	145-152
Off	Off	On	Off	Off	On	On	153-160
Off	Off	On	Off	On	Off	Off	161-168
Off	Off	On	Off	On	Off	On	169-176
Off	Off	On	Off	On	On	Off	177-184
Off	Off	On	Off	On	On	On	185-192
Off	Off	On	On	Off	Off	Off	193-200
Off	Off	On	On	Off	Off	On	201-208
Off	Off	On	On	Off	On	Off	209-216
Off	Off	On	On	Off	On	On	217-224
Off	Off	On	On	On	Off	Off	225-232
Off	Off	On	On	On	Off	On	233-240
Off	Off	On	On	On	On	Off	241-248
Off	Off	On	On	On	On	On	249-256

**TABLE 8.2A 8 CHANNEL ADDRESS SWITCH SETTINGS (1-256)**

This table is used to configure the Channel Address switches on the 7021, 7026, and 7321.

**Note:** If any Datascan set-up switches are changed after power up they will have no effect until the power to the module is removed and then re-applied.

S1	S2	S3	S4	S5	S6	S7	Channel Range
Off	On	Off	Off	Off	Off	Off	257-264
Off	On	Off	Off	Off	Off	On	265-272
Off	On	Off	Off	Off	On	Off	273-280
Off	On	Off	Off	Off	On	On	281-288
Off	On	Off	Off	On	Off	Off	289-296
Off	On	Off	Off	On	Off	On	297-304
Off	On	Off	Off	On	On	Off	305-312
Off	On	Off	Off	On	On	On	313-320
Off	On	Off	On	Off	Off	Off	321-328
Off	On	Off	On	Off	Off	On	329-336
Off	On	Off	On	Off	On	Off	337-344
Off	On	Off	On	Off	On	On	345-352
Off	On	Off	On	On	Off	Off	353-360
Off	On	Off	On	On	Off	On	361-368
Off	On	Off	On	On	On	Off	369-376
Off	On	Off	On	On	On	On	377-384
Off	On	On	Off	Off	Off	Off	385-392
Off	On	On	Off	Off	Off	On	393-400
Off	On	On	Off	Off	On	Off	401-408
Off	On	On	Off	Off	On	On	409-416
Off	On	On	Off	On	Off	Off	417-424
Off	On	On	Off	On	Off	On	425-432
Off	On	On	Off	On	On	Off	433-440
Off	On	On	Off	On	On	On	441-448
Off	On	On	On	Off	Off	Off	449-456
Off	On	On	On	Off	Off	On	457-464
Off	On	On	On	Off	On	Off	465-472
Off	Off	On	On	Off	On	On	573-480
Off	On	On	On	On	Off	Off	481-488
Off	On	On	On	On	Off	On	489-496
Off	On	On	On	On	On	Off	497-504
Off	On	On	On	On	On	On	505-512

**TABLE 8.2B 8 CHANNEL ADDRESS SWITCH SETTINGS (257-512)**

This table is used to configure the Channel Address switches on the 7021, 7026, and 7321.

**Note: If any Datascan set-up switches are changed after power up they will have no effect until the power to the module is removed and then re-applied.**

S1	S2	S3	S4	S5	S6	S7	Channel Range
On	Off	Off	Off	Off	Off	Off	513-520
On	Off	Off	Off	Off	Off	On	521-528
On	Off	Off	Off	Off	On	Off	529-536
On	Off	Off	Off	Off	On	On	537-544
On	Off	Off	Off	On	Off	Off	545-552
On	Off	Off	Off	On	Off	On	553-560
On	Off	Off	Off	On	On	Off	561-568
On	Off	Off	Off	On	On	On	569-576
On	Off	Off	On	Off	Off	Off	577-584
On	Off	Off	On	Off	Off	On	585-592
On	Off	Off	On	Off	On	Off	593-600
On	Off	Off	On	Off	On	On	601-608
On	Off	Off	On	On	Off	Off	609-616
On	Off	Off	On	On	Off	On	617-624
On	Off	Off	On	On	On	Off	625-632
On	Off	Off	On	On	On	On	633-640
On	Off	On	Off	Off	Off	Off	641-648
On	Off	On	Off	Off	Off	On	649-656
On	Off	On	Off	Off	On	Off	657-664
On	Off	On	Off	Off	On	On	665-672
On	Off	On	Off	On	Off	Off	673-680
On	Off	On	Off	On	Off	On	681-688
On	Off	On	Off	On	On	Off	689-696
On	Off	On	Off	On	On	On	697-704
On	Off	On	On	Off	Off	Off	705-712
On	Off	On	On	Off	Off	On	713-720
On	Off	On	On	Off	On	Off	721-728
On	Off	On	On	Off	On	On	729-736
On	Off	On	On	On	Off	Off	737-744
On	Off	On	On	On	Off	On	745-752
On	Off	On	On	On	On	Off	753-760
On	Off	On	On	On	On	On	761-768

**TABLE 8.2C 8 CHANNEL ADDRESS SWITCH SETTINGS (513-768)**

This table is used to configure the Channel Address switches on the 7021, 7026, and 7321.

**Note:** If any Datascan set-up switches are changed after power up they will have no effect until the power to the module is removed and then re-applied.

S1	S2	S3	S4	S5	S6	S7	Channel Range
On	On	Off	Off	Off	Off	Off	769-776
On	On	Off	Off	Off	Off	On	777-784
On	On	Off	Off	Off	On	Off	785-792
On	On	Off	Off	Off	On	On	793-800
On	On	Off	Off	On	Off	Off	801-808
On	On	Off	Off	On	Off	On	809-816
On	On	Off	Off	On	On	Off	817-824
On	On	Off	Off	On	On	On	825-832
On	On	Off	On	Off	Off	Off	833-840
On	On	Off	On	Off	Off	On	841-848
On	On	Off	On	Off	On	Off	849-856
On	On	Off	On	Off	On	On	857-864
On	On	Off	On	On	Off	Off	865-872
On	On	Off	On	On	Off	On	873-880
On	On	Off	On	On	On	Off	881-888
On	On	Off	On	On	On	On	889-896
On	On	On	Off	Off	Off	Off	897-904
On	On	On	Off	Off	Off	On	905-912
On	On	On	Off	Off	On	Off	913-920
On	On	On	Off	Off	On	On	921-928
On	On	On	Off	On	Off	Off	929-936
On	On	On	Off	On	Off	On	937-944
On	On	On	Off	On	On	Off	945-952
On	On	On	Off	On	On	On	953-960
On	On	On	On	Off	Off	Off	961-968
On	On	On	On	Off	Off	On	969-976
On	On	On	On	Off	On	Off	977-984
On	On	On	On	Off	On	On	985-992
On	On	On	On	On	Off	Off	993-1000

TABLE 8.2D 8 CHANNEL SWITCH SETTINGS (769-1000)

This table is used to configure the Channel Address switches on the 7021, 7026, and 7321.

**Note:** If any Datascan set-up switches are changed after power up they will have no effect until the power to the module is removed and then re-applied.

Network Address	S4	S5	S6	S7	S8
0	Off	Off	Off	Off	Off
1	Off	Off	Off	Off	On
2	Off	Off	Off	On	Off
3	Off	Off	Off	On	On
4	Off	Off	On	Off	Off
5	Off	Off	On	Off	On
6	Off	Off	On	On	Off
7	Off	Off	On	On	On
8	Off	On	Off	Off	Off
9	Off	On	Off	Off	On
10	Off	On	Off	On	Off
11	Off	On	Off	On	On
12	Off	On	On	Off	Off
13	Off	On	On	Off	On
14	Off	On	On	On	Off
15	Off	On	On	On	On
16	On	Off	Off	Off	Off
17	On	Off	Off	Off	On
18	On	Off	Off	On	Off
19	On	Off	Off	On	On
20	On	Off	On	Off	Off
21	On	Off	On	Off	On
22	On	Off	On	On	Off
23	On	Off	On	On	On
24	On	On	Off	Off	Off
25	On	On	Off	Off	On
26	On	On	Off	On	Off
27	On	On	Off	On	On
28	On	On	On	Off	Off
29	On	On	On	Off	On
30	On	On	On	On	Off
31	On	On	On	On	On

**TABLE 8.3 NETWORK ADDRESS SWITCH SETTINGS**

This table used to configure the Network Address switches on 7010, 7011, 7320, 7321 and 7327 modules.

**Note:** If any Datascan set-up switches are changed after power up they will have no effect until the power to the module is removed and then re-applied.

Network Address	S4	S5	S6	S7	S8	Channel Range
0	Off	Off	Off	Off	Off	1-16
2	Off	Off	Off	On	Off	17-32
4	Off	Off	On	Off	Off	33-48
6	Off	Off	On	On	Off	49-64
8	Off	On	Off	Off	Off	65-80
10	Off	On	Off	On	Off	81-96
12	Off	On	On	Off	Off	97-112
14	Off	On	On	On	Off	113-128
16	On	Off	Off	Off	Off	129-144
18	On	Off	Off	On	Off	145-160
20	On	Off	On	Off	Off	161-176
22	On	Off	On	On	Off	177-192
24	On	On	Off	Off	Off	193-208
26	On	On	Off	On	Off	209-224
28	On	On	On	Off	Off	225-240
30	On	On	On	On	Off	241-256

**TABLE 8.4 16 CHANNEL MODULE NETWORK AND CHANNEL SWITCH SETTINGS.**

Used to configure both channel address and network address for the 7041, 7220 and 7250 modules.

**Note:** If any Datascan set-up switches are changed after power up they will have no effect until the power to the module is removed and then re-applied.

Network Address	S4	S5	S6	S7	S8	Channel Range
0	Off	Off	Off	Off	Off	1-8
1	Off	Off	Off	Off	On	9-16
2	Off	Off	Off	On	Off	17-24
3	Off	Off	Off	On	On	25-32
4	Off	Off	On	Off	Off	33-40
5	Off	Off	On	Off	On	41-48
6	Off	Off	On	On	Off	49-56
7	Off	Off	On	On	On	57-64
8	Off	On	Off	Off	Off	65-72
9	Off	On	Off	Off	On	73-80
10	Off	On	Off	On	Off	81-88
11	Off	On	Off	On	On	89-96
12	Off	On	On	Off	Off	97-104
13	Off	On	On	Off	On	105-112
14	Off	On	On	On	Off	113-120
15	Off	On	On	On	On	121-128
16	On	Off	Off	Off	Off	129-136
17	On	Off	Off	Off	On	137-144
18	On	Off	Off	On	Off	145-152
19	On	Off	Off	On	On	153-160
20	On	Off	On	Off	Off	161-168
21	On	Off	On	Off	On	169-176
22	On	Off	On	On	Off	177-184
23	On	Off	On	On	On	185-192
24	On	On	Off	Off	Off	193-200
25	On	On	Off	Off	On	201-208
26	On	On	Off	On	Off	209-216
27	On	On	Off	On	On	217-224
28	On	On	On	Off	Off	225-232
29	On	On	On	Off	On	233-240
30	On	On	On	On	Off	241-248
31	On	On	On	On	On	249-256

**TABLE 8.5 8 CHANNEL MODULE NETWORK & CHANNEL SWITCH SETTINGS**

Used to configure both the channel and network address switches on the 7221 modules.

**Note:** If any Datascan set-up switches are changed after power up they will have no effect until the power to the module is removed and then re-applied.

---

## 9. Troubleshooting

---

**Note:****Some of the following actions will:**

**Interrupt all communications with the host computer on the Datascan network,  
Reset all the Datascan configuration to factory default,  
Modify some of your Datascan configuration.**

**Before following the items below, please ensure:**

**You have proper authorisation to change the system,  
Your configuration is backed up in your host computer, as this will be the only means of reconfiguring your system,  
You have warned relevant staff/operators on site.**

### 9.1 Typical Problems

If your Datascan system is not functioning correctly check the following items and follow the guidelines given before contacting your distributor for support:

#### 9.1.1 No host communications

Is the RS232 cable correctly wired ? (see Section 2.2.5)  
Maximum RS232 distance should be 10 Metres, is this the case ?  
Is the baud rate set correctly in the host package and on the Datascan ?

##### 9.1.1.1 Remedies

Power down and up to register baud rate changes.  
Use a dumb terminal emulation and press return, a \* or \$ prompt should be returned.  
Try a Datascan Hardware reset. (See Section 9.1.4).

#### 9.1.2 Incorrect readings

Is the ADC light on when scanning analog inputs ?  
Is the channel type set correctly in the software ?  
Is the common mode specification of the module breached ? (See Section 6.1)  
Is the sensor wired correctly ? (See Section 6)  
On Analog modules set the scanner to CJC mode and read this value ?  
Are unused channels shorted individually ?  
Is the channel type supported on the module being used ? (See Section 6)  
Maximum scanner cable distance is 10 Metres, is this the case ?

### **9.1.2.1 Remedies.**

Short all unused channels.

Measure earth potentials between any two channels, this should not be more than 12 Volts. (See Section 6.1)

Try a Datascan hardware reset on the processor concerned.(See Section 9.1.4)

### **9.1.3 No networking facilities**

Is the network terminated at each end with the terminators supplied? (See Section 2.2.4)

Is the RS485 cable of the correct specification?

Is the RS485 cable shorted or cut?

Have the modules all got unique addresses?

Is the RS485 cable located in cable trunking where other high voltages are present?

Maximum RS485 distance 1.2km, is this the case?

The maximum number of processors on a network is 32, is this the case?

#### **9.1.3.1 Remedies**

Check the cable for continuity.

Minimize the system to two processors with 1 metre of cable and then add processors.

Try a Datascan hardware reset on all processors.

### **9.1.4 Datascan Hardware reset.**

Any Datascan processor can be reset by following the steps below, this applies to 7010, 7200 and 7300 series processors.

1. Note the current DIP switch settings of the processor.
2. Set all the DIP switches on the processor to 1 or on.
3. Power up the Datascan module, all LED's should flash, indicating a reset.
4. Reset the DIP switches to their original position and power up again.

The above actions have the effect of disabling the onboard battery backup and setting the memory to factory defaults. If a host package has sent spurious or incorrect commands to the unit this can be used to reinitialise the module.

### **9.1.5 Powering up the Datascan**

When the Baud rate or address of any Datascan module in a system is changed, the processor must be powered down and up for the change to registered and used.

---

## 9.1.6 LED Status indicators

Each 7010, 7011, 7041, 7300 and 7200 processor modules have LED status indicators, which can be used extensively for faultfinding.

### 9.1.6.1 Power LED fails to come on

There are two main reasons for this:

1. Is there 24 Volts DC present at the Power connector?
2. Is there more than 32 nodes on the Datascan network?

### 9.1.6.2 RS232 LED not flashing when attempting to communicate.

1. Is the RS232 Cable wired correctly?
2. Is the Datascan module Baud rate set to the correct speed?

The light will flash even if the Baud rate is set incorrectly.  
Try a Datascan hardware reset.

### 9.1.6.3 ADC LED fails to come on when scanning or flashes.

It is normal for the LED to blink occasionally when an Analog to Digital Conversion is performed. If the module is continuously scanning then the LED will stay on all the time.

If the processor is connected only to digital channels i.e. 7031/35/36 the ADC will not be use.

If the channels connected to that processor are outside the channels scanned the LED will not light.

Some drivers implement the Single shot mode of scanning resulting in a flash of the LED when the measurement is taken. Check with your software vendor.

### 9.1.6.4 NET LED will not come on when networked.

The NET or Network LED will only light when the processing unit can see other uniquely addressed processors connected to it.

The Datascan RS485 network is totally self configuring and will only produce problems when:

1. Check the twisted pair cable used to ensure continuity.
2. Check that all processors on the network are given unique addresses.
3. Minimize the system to two processors with a short one-metre cable and terminators and gradually build the system until the problem node is found.
4. Disconnect any scanner modules from the processors by the ribbon cable. (Power down first) then repower.

5. Un-power all nodes and try the hardware reset described above, then repower the processors.
6. Toggle the DIP switches to clear any accumulated contact contamination.

## 9.2 General guidelines for a fault free system

### 9.2.1 Configuration Switches

Each Datascan module has one or two sets of in line switches for the selection of:

1. RS232 speed
2. Mains frequency
3. Network address
4. Channel address

Care should be taken to ensure that the switches are fully set to either the 0 or 1 position, and that these provide the correct baud rate e.g. 9600, Mains frequency e.g. 50 or 60hz and address.

As part of a maintenance program all switches should be moved and reset to their original positions on a 12 monthly basis to help offset contamination. Contamination may occur during shipment and so may not have been present during final test.

### 9.2.2 Unused inputs

All unused inputs should be set to a defined input. This is best achieved by shorting all poles on a given channel for each unused channel. This helps alleviate floating inputs and range hunting on certain scanner modules.

### 9.2.3 Analog inputs

All analog inputs should have the guard terminal connected as per the connection details.

All thermocouple inputs should follow the guidelines laid out in the manual.

All 4-20ma current transducers connected to Datascan should have an external precision 62-Ohm resistor fitted across the High and Low terminal. This enables the scanner to measure the voltage developed across it and convert it internally to a current reading.

## 9.2.4 Analog outputs

The 7050 scanner module requires an external 24 Volt DC Power Supply when any of the outputs are used in current mode. This is connected to the scanner module directly, and is in addition to the power provided to it via the processor module.

## 9.2.5 Common mode problems with non isolated modules

If the unit you are using is a non-isolated scanner i.e. 7X20 or 7X21 a maximum of 12 Volts potential between any two channels is the maximum permissible. This can be a problem in installations where the earth levels of the transducers, particularly 4-20ma, or peripheral equipment are at a higher potential than the earth level used by the Datascan system.

If the common mode performance of the system is exceeded Datascan will behave in an unpredictable fashion causing spurious readings and unexpected results.

The problem is not generally with one earth, but with many that may force the inputs to be out of the common mode range. If a large number of scanners are connected to a processor, the problem channel could be on a totally different module to the one giving the spurious readings.

All inputs should be maintained relative to one common Earth, which can be referenced to the Datascan Earth.

## 9.2.6 Network termination

When using the RS485 network facilities of Datascan, both ends of the network should be terminated with the terminators supplied. These stop reflections on the network and ensure reliable data transmission and integrity.

## 9.2.7 Channel Addressing

Each scanner module on a Datascan system must have a unique address. 7200 series and 7041 modules only support channel addresses in the range 1-256.

16 Channel scanner modules i.e. 7X20/21 can only be placed on a 16 channel boundary.

A maximum of 32 processing units (nodes) can be supported on each network. The 7011, 7041 modules all count as 1 node.

## 9.3 Troubleshooting Using Windows Terminal Emulator

A simple way to test your Datascan hardware when problems are encountered is to use the Terminal Emulator supplied with Windows. This allows you to talk directly to Datascan using ASCII software commands and therefore suppress any possible problems related to the host software used.

The Windows Terminal Emulator can be found in the Accessories programme group.

Before sending software commands to the processor, you need to configure the terminal emulator so that it can successfully communicate with Datascan.

### 9.3.1 Configuring Windows Terminal

You will find in the Settings Menu all the following configuration options.

In each of the following Dialog Boxes, the selected options are the ones required to get your system going.

#### 9.3.1.1 RS232 Communication Configuration.

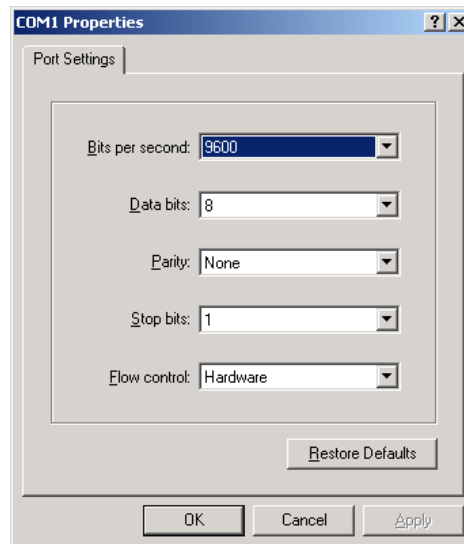

Defines the Communications: hardware, data transfer speed, and protocol to use.

Baud Rate : Choose the appropriate rate according to the DIP switch setting on the processor to which your PC is connected, i.e. 9,600 or 19,200 Baud.

### 9.3.1.2 Terminal Emulation

Defines the type of terminal to be emulated

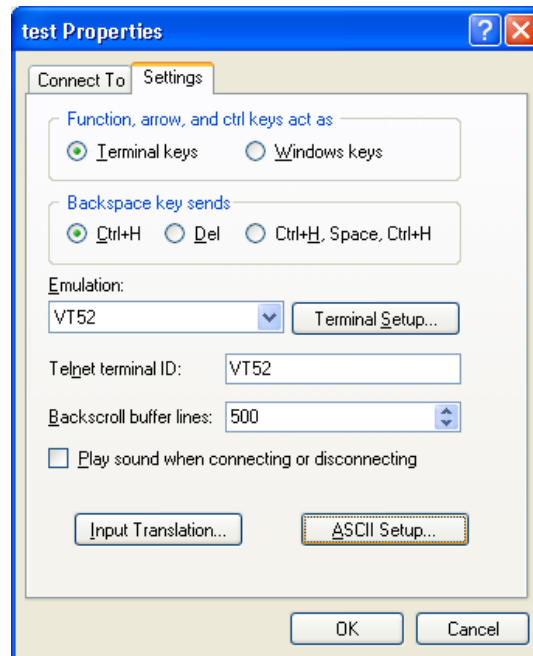

### 9.3.1.3 Terminal Preferences

Sets the various options referring to the terminal i.e. Line Feed (LF), Carriage Return (CR) etc...

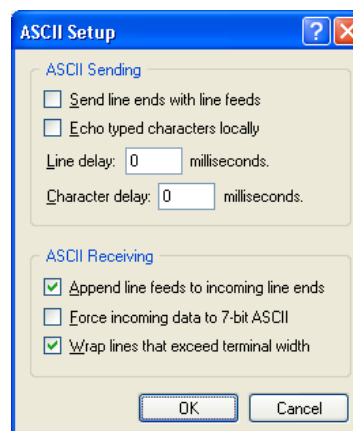

NB: **Local Echo** : Ctrl + E is the first command you need to send to Datascan to set the serial communications to a known mode.

## 9.3.2 Talking To Datascan

Note : To validate any command you need to press the Return key.

### 9.3.2.1 Resetting the RS232 Datascan Communications.

Press **Ctrl+E** This command forces the Datascan unit to terminate whatever it is doing on the RS232 line and sets the RS232 protocol to Echo On and No handshake. The Echo enables the user to verify the characters entered at the keyboard.

### 9.3.2.2 Is My Terminal / Datascan Communicating?

Press any key: You should see the corresponding character on the screen and the RS232 LED on the Datascan Measurement processor flash.

Press the Return key A '\$' or '\*' prompt should appear on the screen.

Type 'iv' then Return: Datascan should give you the firmware version of the PROM fitted in the unit with either a '\$' or a '\*' prompt.

At this point if Datascan is not responding correctly you need to check that all the above options have been correctly selected and that your RS232 cable is wired properly and works. Having done that if Datascan still fails to respond then contact your local dealer for support.

### 9.3.2.3 Reset Datascan

Type the following commands ending each with a RETURN.

TC This is to gain control of the Datascan system, the reply prompt should be a '\$'.

TR This command resets the Datascan System, clears any configurations stored in memory and leaves the processor in listener mode. The reply prompt should be a '\*'.

TC This command puts the Measurement Processor into controller mode, the reply prompt should be a '\$'.

The following shows an example of the Terminal Screen after these commands have been sent.

```

Terminal - (Untitled)
File Edit Settings Phone Transfers Help
*
*tc
$tr
*tc
$iv
DATASCAN VERSION 2.00 25-03-92 1

```

### 9.3.2.4 Configuring The Datascan System

Simple configuration of the Datascan System is done using two commands.

CT to set one or a group of channel to a certain type.

CS to specify the range and speed/resolution of measurements taken.

To set channel 1 to 8 with millivolt voltage, 16 bits, autorange send the following commands:

CT1,8,2 ' sets ch 1 to 8 to millivolt input type

CS1,8,0,1 ' specify autorange and 16 bit.

Refer to the software commands section of the Datascan Technical Reference Manual for more details.

Note : You can perform sensible measurements without any inputs connected to the unit by measuring the on board thermistor used to measure the cold junction of thermocouples. By setting the input type to CJC,type number 13, Datascan measures the ambient temperature where the module's located. This facility is very useful to verify the unit.

### 9.3.2.5 Getting Results from Datascan

There are two ways to read a single channel or group of channels

#### One-off report of data

You need to set standard report format, start scanning the channels you want and then request the data. This is done by the following set of commands (example for the 8 first channels):

RM 0 ' sets standard report format

SC1,8 ' starts scanning channel 1 to 8

RL1,8 ' requests the reading of channel 1 to 8

This will give the first 8 channel results in ASCII characters to the screen.

As an example the screen below shows the configuration and report of channels 1 to 4.

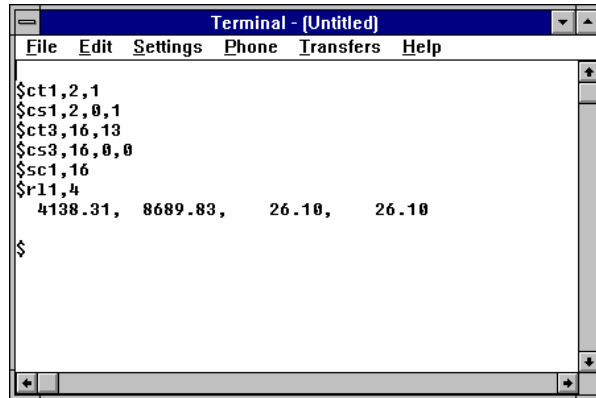

```
Terminal - (Untitled)
File Edit Settings Phone Transfers Help
$ct1,2,1
$cs1,2,0,1
$ct3,16,13
$cs3,16,0,0
$sc1,16
$r11,4
  4138.31,  8689.83,   26.10,   26.10
$
```

### Continuous report of data or monitor page

The following explain how to configure and run simple monitor for 16 channels.

You need to set the monitor page, start scanning the channels you want, and then run the monitor page. This is done by the following set of commands:

```
RM 0      ' sets standard report mode.
MA 1,16,1 ' add channel 1 to 16 to display in monitor page 1.
MF0,*1    ' set display format to VT52 terminal mode.
SC1,16    ' starts scanning channel f to l
MR 1      ' run monitor page 1
```

Press ESC to exit the monitor page. You should get a prompt again.

### 9.3.2.6 Example of a Continuous report of data or monitor page

You can setup to 10 pages of monitoring data with up to 16 channels of each of these page. Follows a set of commands to set channel 1 to 16 to monitor page 1.

## Commands sent:

```

CT1,2,1      ' sets ch1 to 2 to microvolt input
CS1,2,1,1    ' sets ch1 to 2 to 20mV range, 16 bit
CT3,16,13    ' sets ch 3 to 16 to CJC inputs
CS3,16,0,0   ' sets ch 3 to 16 to autorange, 14bit
SC1,16       ' start scanning ch 1 to 16
RM1          ' report mode 1
MA1,16,1     ' add ch 1 to 16 to monitor page 1
MF0,*1       ' defines VT52 monitor format
.....       ' Optional commands
MR1          ' run monitor page 1

```

## Optional commands :

```

MTEExample ,1 ' sets 'Example' as title of monitor page
CL1,1,Boiler1 ' sets 'Boiler1' label to channel 1
CL1,2,Boiler2 ' sets 'Boiler2' label to channel 2
CL1,3,AmbientT ' sets 'Ambient' label to channel 3
CU1,2,4       ' sets uV unit for ch 1 to 2
CU3,16,17     ' sets 'C unit for ch 3 to 16
CA1,1,10000,1000 ' Sets a High alarm of 10,000 (AH tag) and a Low Alarm (AL tag) of 1000 on ch1
FT 10.30.00   ' sets time

```

```

Terminal - (Untitled)
File Edit Settings Phone Transfers Help
10:35:34

                          Example

Ch.  1 Boiler1  10350.86 uV AH  Ch.  2 Boiler2  8638.50 uV
Ch.  3 AmbientT  24.47 `C  Ch.  4 ANALOG_I  24.47 `C
Ch.  5 ANALOG_I  24.47 `C  Ch.  6 ANALOG_I  24.47 `C
Ch.  7 ANALOG_I  24.47 `C  Ch.  8 ANALOG_I  24.47 `C
Ch.  9 ANALOG_I  24.80 `C  Ch. 10 ANALOG_I  24.80 `C
Ch. 11 ANALOG_I  24.80 `C  Ch. 12 ANALOG_I  24.80 `C
Ch. 13 ANALOG_I  24.80 `C  Ch. 14 ANALOG_I  24.80 `C
Ch. 15 ANALOG_I  24.80 `C  Ch. 16 ANALOG_I  24.80 `C

```



---

## 10. Datascan errors

---

### 10.1 Command Errors

**Datascan performs very extensive error checking on commands that are entered, leaving the user with a high degree of confidence in the commands syntax.**

- #001 Cannot initialise communication link to Datascan.
- #002 Datascan response unexpected at this time.
- #003 Command didn't parse, returned only '?'
- #004 Communication timeout.
- #005 Timeout value too small.
- #006 Incorrect Datascan response.
- #007 Tried three times to get correct binary results packet and failed.
- #010 Datascan did not understand command.
- #011 Channel number out of range.
- #012 Channel specified is not on the Datascan network.
- #013 Channel type is not compatible with command type.
- #014 Channel node is not compatible with command type.
- #015 Datascan network is not up. Required for external content in command.
- #016 Command needs control to be actioned.
- #017 Parameter error in command.
- #018 Input error. Overrun or Framing Error on input of command.
- #019 Command is not allowed.
- #020 Command not allowed in continuous scanning.

## 10.2 Result Errors

These errors are encoded within the channel results and are returned on a per channel basis in response to the Report Channel data commands (RL & RS).

- #1 Illegal channel mode type.
- #2 Channel overload.
- #3 Drift correct error.
- #4 Unknown channel node type.
- #5 Linearisation error.
- #6 No valid data for channel.
- #7 Math calculation error.
- #8 Channel not being scanned.
- #9 Channel not on system.
- #10 Channel set to skip.
- #11 Measurement rate too high to linearise.
- #12 Measurement rate too low to linearise.
- #13 Channel node duplicated.
- #14 Channel node is a dummy.
- #15 Channel value too large for this output format.
- #16 Channel value too negatively large for this output format.

Further information on all errors listed in this section can be found in the Datascan commands implementation manual.

---

# 11. Index

---

- Analog Input* .....
  - 2 Pole*..... 31, 38, 39, 40
  - 3 Pole*..... 29, 31, 41
  - 6 Pole*..... 29, 48
  - Current Source*... 40, 43, 47, 50
  - Strain Gauge* ..... 29, 30, 31, 52, 54
  - Thermocouple*..... 39, 42, 46, 49
  - Voltage Source*... 38, 41, 45, 48
- Analog Outputs*
  - Current* ..... 60
  - Voltage* ..... 14, 15, 60
- Channel Address*..... 12, 13, 26, 74, 77
- Channel Address Tables*... 63
- Common Mode Rejection*.. 36, 40, 44, 55
- Datascan Errors* ..... 85, 86
- Datascan Hardware Reset* 73,74,75,76
- Datascan Software Reset*.. 80
- Digital Inputs*..... iv, 15, 56
  - Volt Free*..... 13, 15, 33, 57
- Digital Outputs* ..... 59
- Installation*
  - Earthing Stud*..... 17
  - Physical* ..... 9
- Isolation*..... 6, 37
- LED Indicators* ..... 28, 75, 79
- Noise Rejection* ..... 17, 35
- Overload Protection* ..... 58
- Power Supply*..... 1, 5, 17, 33, 34, 36, 56, 57
- RS232* ..... 1, 4, 5, 6, 10, 11, 12, 16, 20, 21, 29, 34, 61, 73, 75, 76,78, 79,80
  - Baud Rate* ..... 10, 11, 12, 16, 20, 78
  - Protocol*..... 20
- RS485 Network*
  - Gateway module*. 5, 27, 28, 61
  - Network Address*. 26, 27, 28, 63, 71, 72
  - Network Cable*.... 6, 18
  - Network* ..... 1, 2, 4, 5, 6, 10, 11, 15, 16, 18, 25, 27, 29, 34, 61,74,75,77
  - Termination* ..... 19
- Scanner Expansion Bus* .... 4, 5, 25, 30, 31
- Terminal Emulator* ..... 78
- Troubleshooting*..... 73,78



